



Nidec-Avtron Makes the Most Reliable Encoders in the World

8901 E. PLEASANT VALLEY ROAD • INDEPENDENCE, OHIO 44131-5508  
**TELEPHONE:** (1) 216-642-1230 • **FAX:** (1) 216-642-6037  
**E-MAIL:** tachs@nidec-avtron.com • **WEB:** www.avtronencoders.com

# Encoder Instructions

## MODEL AV85 8 1/2" C-Face MOUNT MODULAR

### DESCRIPTION

The Avtron AV85 is a modular, two piece incremental encoder (also known as a tachometer or rotary pulse generator). It provides a two phase, A Quad B frequency (pulse) output, with complements. The AV85 mounts on a 8.5" (NEMA FC) Face.

Because the AV85 is modular, there are no bearings or couplings required. This, combined with the latest magnetoresistive (MR) sensor technology, allows the AV85 to provide superior mechanical performance and increased reliability.

An Avtron AV85 can be configured with one or two independent outputs. Each output has six signals: (A, B) 90° out of phase, with complements (Ā, B̄). A marker pulse with complement (Z, Z̄) is also provided.

Output resolution on the AV85 is determined by the sensor only. Unlike older models, any PPRs can be mixed and matched. Selection of the rotor is based only on the shaft mounting requirements (and not PPR).

### Equipment Needed for Installation

Provided	Optional	Not Provided
AV85 Stator/Housing Socket Hd Cap Screw 1/2"-13 x 1.50" (4)	Extended Shaft Cover w/ Screws 6-32 x 0.31" (4)	Phillips Screwdriver 2mm Hex Wrench (T-Handle)
AV85 Rotor Socket Set Screw #M4 x 8mm (2) or Pre-Installed Cam Screw or End-of-Shaft w/ screws: CD 180-320 3/8"-16 x1" + pin CD360 10-24 x 0.5" (2) CD400, 500 3/8"-16 x 0.88" (2) Thread locker (blue)	Flat Cover w/Screws 10-24 x 0.38" (4) Lock Washers Thru Shaft Cover w/ Screws 10-24 x 0.38" (4) w/ V-Ring Seal and Silicone Lubricant	Style for Large-bore Thru-Shaft Rotors) 3mm Hex Wrench (T-Handle) Style for Cam Screw Rotors) 3/8" Hex Wrench (T-Handle) Style for Stator/Housing) <b>End-of-Shaft ONLY</b> 5/32" Hex Wrench 5/16" Hex Wrench 9/16" Wrench

### AV85 PART NUMBERS AND AVAILABLE OPTIONS

Model	Housing Type	Shaft Size (Thru Shaft Rotor)	Cover Style	Line Driver	Single/Left Output (PPR)	Right Output (PPR)	Connector	Modifications
AV85A	1- Single Output 2- Dual Output	C0- Non-std. Shaft Size XX- None  Thru Shaft Rotor (Metric) US Metric CA- 0.500 D2- 10mm CB- 0.625 D3- 12mm CC- 0.875 DB- 14mm CD- 0.938 DC- 15mm CE- 1.000 DD- 16mm CF- 1.125 D4- 18mm CG- 1.250 DE- 19mm CH- 1.375 DF- 24mm CT- 1.500 DG- 28mm CJ- 1.625 DH- 30mm CK- 1.750 DT- 32mm CL- 1.875 DJ- 36mm CM- 2.000 DK- 38mm CN- 2.125 DL- 42mm CQ- 2.250 DM- 45mm CP- 2.375 DN- 48mm CR- 2.500 DP- 52mm TS- 2.625* DR- 55mm TU- 2.875* DS- 60mm TV- 3.000* MU- 65mm* T4- 3.125* MV- 70mm* T7- 3.188* MW- 75mm* MY- 80mm* MZ- 85mm*	E- Extended Shaft Cover F- Flat Cover T- Flat Thru-Hole Cover with Shaft Seal D- Dome Cover	6- 5-24V in/out 8- 5-24 V in, 5-15 V out high power 9- 5-24V in, 5V out	0- Non-std. R- 512 S- 600 CA-50 V- 900 F- 60 J- 960 G- 100 Y- 1024 H- 120 Z- 1200 A- 128 A^1270 BA-150 3- 2000 L- 240 4- 2048 N- 256 5- 2500 P- 300 D- 4096 E- 360 8- 4800 B- 480 9- 5000 Q- 500	CA-50 J- 960 F- 60 Y- 1024 G- 100 Z- 1200 H- 120 A^1270 A- 128 3- 2000 BA-150 4- 2048 L- 240 5- 2500 N- 256 D- 4096 P- 300 8- 4800 E- 360 9- 5000 B- 480 0- Non-std. S- 600 X- None V- 900	W- 18" flex. cable L- 18" cable w/r angle grommet	000-No Modification 002 <sup>2</sup> -select alternate PPR assignment code 004- Add Housing Drain (single output only) 005-Super Magnetic Shielding 4xx-Special PPR PPR-Enter 0 in the PPR code(s), select the special option code below 9xx-Special Cable Length, xx=length in feet 00W- Connector on 18" cable: Use w/ options "T", "U"

\* Set Screw Rotor only  
 ^ To specify this PPR, also specify modification code 002.

SPECIAL PPR OPTION CODES		
OPTION CODE	LEFT PPR	RIGHT PPR
401	1270	None
402	150	None
403	50	None
404	512	16
405	16	None
406	6000	None
407	2800	None
408	1400	None
409	30	None

Connector Options								
Mounted on Encoder				Mounted on 18" cable				00W
10 Pin MS	10 Pin EPIC	10 Pin mini MS	7 Pin MS	10 Pin MS	8 Pin M12	10 Pin EPIC	10 Pin mini MS	(*)8 Pin M12
A- w/o plug (std. phasing) B- w/o plug (Dynapar HS35 phasing) C- "A" w/ plug D- "B" w/ plug	G- w/ plug Northstar pinout P- w/ plug	R- w/ plug	J- w/o plug	Y- w/o plug on conduit box	T- w/o plug (Turck Pinout) U- w/o plug (US Pinout)	Q- w/o plug on remote mount blade Z- w/ plug	S- w/ plug	T- w/o plug (Turck Pinout) U- w/o plug (US Pinout)

(\*)Requires Special option 00W

FIGURE 2

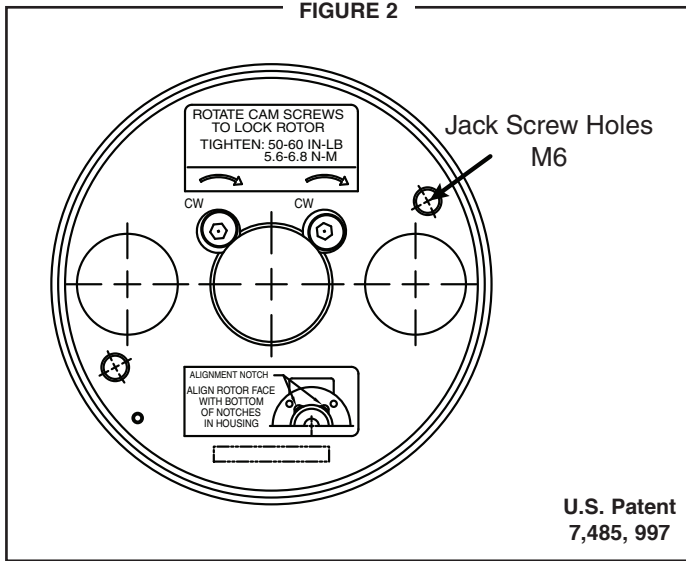

**NOTE**  
Special option 002 selects an alternate PPR code definition. Example: A-128 PPR with option code 000. A<sup>^</sup>-1270 PPR with option code 002.

**INSTALLATION**

Installation and removal videos for the AV56/67/85/115 are available on Avtron's web site. Refer to the back page of these instructions for outline and mounting dimensions. The motor must comply with 1998 NEMA MG 1, section 4, for tolerances on diameters and runout for shafts and accessory faces. Axial float or endplay must be less than ±0.050".

In preparation for installing the Model AV85 encoder, it is first necessary to clean both the accessory motor shaft and the mounting face. These surfaces must be inspected and any paint, burrs, or other surface imperfections removed.

Installation procedures should be performed only by qualified

personnel. Safety precautions must be taken to ensure machinery cannot rotate and all sources of power are removed during installation.

**ROTOR INSTALLATION**

For set screw and end-of-shaft rotors only: Apply anti-seize compound to the motor shaft. For all rotors: Slide the rotor onto the shaft with the marking "Motor side" facing in, (toward the motor face). The rotor centerline must match the sensor centerline. To accomplish this, use the rotor locating gauge (A28505) and slide the rotor onto the shaft until it is in the proper position as shown in Figure 1. If a gauge is not available, use the stator housing alignment grooves as show in Figure 3.

**STANDARD CAM SCREW ROTOR INSTALLATION**

The motor shaft must extend at least 0.63" from the motor face. Turn the cam screws of the rotor in the directions shown on the rotor to engage the cams. Tighten to 50-60 in-lb [5.6 - 6.8 N-m] (See Figure 2) using the 3mm hex wrench. Total cam screw rotation will be less than one turn.

**CAUTION**

**Do not adjust the cam screws before motor shaft mounting; bottoming out the screws, or backing them out excessively, can lead to insufficient shaft holding force. Thread locker is preapplied on the cam screws.**

**LARGE BORE SET SCREW ROTOR INSTALLATION**

The motor shaft must extend at least 0.63" from the motor face. Apply thread locker to the rotor set screw holes, preferably from the inside of the rotor bore before mounting. Tighten the rotor set screws to 15 in-lb [2 N-m] using the 2mm T-handle hex wrench.

**CAUTION**

**Use only a T-handle or torque hex wrench to tighten set screws; using a right angle wrench will not provide enough holding force, and the rotor may slip.**

**SPECIFICATIONS**

**ELECTRICAL**

- A. Operating Power (Vin)
  - 1. Volts.....5-24 VDC
  - 2. Current .....100mA, each output, no load
- B. Output Format
  - 1. 2Ø & Comp .....A, A̅, B, B̅ (differential line driver)
  - 2. Marker .....1/Rev, Z, Z̅
- C. Signal Type .....Incremental, Square Wave, 50 ±10% Duty Cycle.
- D. Direction Sensing.....ØA leads ØB for CW rotation as viewed from the back of the tach looking at the non-drive end of the motor.
- E. Phase Sep. ....15% minimum
- F. Frequency Range.....0 to 165,000 Hz
- G. PPR.....8-5000
- H. Line Driver Specs.....See table
- I. Connectors .....See connector options on page 1
- J. Integral LED Indicator ..GREEN: power on, unit ok. RED: alarm on

**MECHANICAL**

- A. Rotor Inertia:.....0.17-0.36 Oz. In. Sec.<sup>2</sup>
- B. Acceleration:.....5000 RPM/Sec. Max.
- C. Speed:.....5400 RPM Max.
- D. Weight:.....2-3 lbs [0.9kg to 1.36kg].
- E. Sensor to Rotor
  - Air Gap (nominal):.....0.030" [0.76mm]
  - Tolerance: .....0.015" [0.38mm]
- F. Rotor Axial Tolerance.±0.050" [±1.27mm]

**ENVIRONMENTAL**

Solid cast aluminum stator and rotor  
Fully potted electronics, protected against oil and water spray  
V-Ring seals provided on through shaft covers  
Operating Temperature:.....-40 to 100°C, 0-100% condensing humidity  
Vibration: 18 g's  
Shock: 1 meter drop test

**LINE DRIVER OPTIONS**

Electrical Specifications		LINE DRIVER OPTIONS			
		6	8	9	Units
Input Voltage		5-24	5-24	5-24	VDC
Nom Output Voltage		5-24	5-15	5	VDC
Line Driver		7272	4125	7272	
Output Resistance Typ		13	3	13	ohms
Maximum Peak Current		1500	3000	1500	mA
Maximum Average Current		120	350	120	mA
Voh Typ		VIN-1	VIN-1, max 15V out	VIN-1	VDC
Vol Typ		0.5	0.4	0.5	VDC
Cable Drive Capacity		1000' @ 5V 500' @ 12V 200' @ 24V	1000'	1000'	feet
Protection	Reverse Voltage	yes	yes	yes	
	Short Circuit	yes	yes	yes	
	Transient	yes	yes	yes	
Alarm	+V(out)	Output voltage equal to input voltage.			
	Alarm*	Open collector, normally off, goes low on alarm, sink 100mA max, 50VDC max			
	LED	Green=power on, Red=Alarm			
Marker		One per revolution. Pulse width approximately 1/128 of a revolution			

\*Alarm not available on connector option "G" (Northstar™ compatible pinout)

## END-OF-SHAFT ROTOR INSTALLATION

The motor shaft must project 0.40" +/- 0.05" [10.2mm +/- 1.3mm] from the motor face including axial end play. Mount the rotors using the hardware supplied. See accompanying chart. On 180 through 320 frame motors, a roll pin is used to prevent rotation of the rotor on the motor shaft. Check that the rotor fits on easily without resistance. The hardware should not be used to force the rotor onto the shaft. Install the pin in the rotor, then position the rotor on the shaft. Lightly tap into place. Install the center bolt and flat washer with springlock washer and tighten. The position of the installed rotor can be verified using the gauge as shown in figure 1, or later, using the housing alignment grooves after housing installation (Figure 3).

## STATOR HOUSING INSTALLATION

The stator housing is attached to the motor using four socket head cap screws (4) 1/2"-13, locating on a 7.25" bolt circle. Longer bolts (not included), are required for sandwich installation between a motor and a brake. Install the four mounting bolts using thread locker and torque to approximately 30-35 ft-lbs [40-47N-m] using the 3/8" T-handle hex wrench.

## VERIFY ROTOR LOCATION

To ensure the rotor is properly located on the shaft: remove the back cover if factory-preinstalled, and verify that the outer face of the rotor is at the same depth as the alignment grooves, using a straight edge tool. (Figure 3)

### CAUTION

**Do not use silicone sealants or caulk of any kind on the motor or encoder face; these can cause misalignment or sensor scraping damage. The AV85 electronics are fully sealed; water may enter and leave the rotor area as needed. A drain hole option is available if frequent moisture buildup is expected.**

## COVER INSTALLATION

Covers must not interfere with the motor shaft or rotor. The longest shaft that can be used without interfering is 0.93" [23.6mm] with a standard flat cover (Cover Style option "F") and 2.75" [70mm] with an extended "pie pan" cover (Cover Style option "E"). Through shaft covers with seals are available for other applications (Cover Style option "T").

## EXTENDED COVER MOUNT

(Cover Style option "E")

The extended cover mounts to the encoder housing using quantity 4 #6-32 x 0.31" screws, lock washers, and thread locker.

## THRU SHAFT AND FLAT COVER INSTALLATION

(Cover Style option "T" and "F")

### NOTE:

**Be sure to apply threadlocker to the screws for thru and flat cover mounting.**

The thru-shaft and flat covers mount to the encoder housing using quantity (4) #10-24 x 0.38" shallow head screws. For thru-shaft applications with outboard brakes, be sure to use only these screws and thread locker; washers or thicker screw heads may interfere with the outboard brake mounting.

## V-RING INSTALLATION FOR THRU SHAFT COVERS

(Cover Style option "T")

For thru shaft covers, verify that the shaft passes completely through the hole in the cover. Apply a small amount of silicone lubricant to the cover plate around the thru shaft hole. The V-Ring seal should compress axially when it is pressed against the clean, smooth face of the cover plate. See Figure 4 for proper installation and V-Ring compression.

## WIRING

### Caution

**Be sure to remove power before wiring the encoder. Be sure to ground the cable shield: It can be connected to case ground at the encoder, or grounded as the receiving device, but should not be grounded on both ends. See note below for Danaher/Northstar wiring.**

Refer to the wiring diagrams for specific information on each option.

The AV85 can be wired for single phase or two phase, either with or without complements, with or without markers. For bidirectional operation, Phase A channel leads phase B channel for clockwise shaft rotation as viewed from the anti-drive or accessory end of the motor (AV85 mounting end).

### NOTE

**Wiring option "G" provides a pinout compatible with Northstar™ encoders, with a cable shield connection on pin 10. Note that this option does not ground the shield; Avtron still recommends grounding the shield at the drive end of the cable for all wiring options.**

## CORRECTIVE ACTION FOR PHASE REVERSAL

- 1) Remove Power.
- 2) Exchange wires on cable, either at encoder cable end, or at speed controller end (but not both).
  - a) Single Ended 2 Phase Wiring (see wiring diagram) Exchange A and B at the use end of the wires.
  - b) Differential 2 Phase Wiring (see wiring diagram) Exchange either A with  $\bar{A}$  in the phase A pair OR B with B in the phase B pair but NOT both.
- 3) Apply Power.
- 4) Verify encoder feedback is correct, using hand rotation of shaft, or jog mode of the speed controller.

Interconnecting cables specified in the wire selection chart are based on typical applications. Physical properties of cable such as abrasion, temperature, tensile strength, solvents, etc., are dictated by the specific application. General electrical requirements are: stranded copper, 22 through 16 AWG (Industrial EPIC connector type options can use 14 AWG), each wire pair individually shielded with braid or foil with drain wire, .05 uf of maximum total mutual or direct capacitance, outer sheath insulator. See specifications for maximum cable length. Stranded 22 AWG wire should not be used for cable runs greater than 61 meters. If 22 AWG is used with EPIC type connector options the wire ends should be tinned.

## FAULT-CHECK

After power-up and the rotor position is checked by the sensor, the Fault-Check LED will turn green.

If the adaptive electronics reach their adjustment limit for any reason, the Fault-Check alarm and LED will notify the drive and operator of an impending failure. The LED will turn red if the Adaptive Electronics reach their adjustment limit. This output occurs before an actual failure, allowing steps to be taken to replace the unit before it causes unscheduled downtime. Fault-Check annunciation is available as an "alarm" output through the connector and as an integral LED.

## TROUBLESHOOTING

If the drive indicates a loss of encoder/tach fault and the AV85 fault-check LED is not illuminated, check the encoder power supply. If power is present, check polarity; one indicator of reversed power supply is that all outputs will be high at the same time. If the drive indicates encoder fault, but the LED shows GREEN, then check the wiring between the drive and the encoder. If the wiring appears correct and in good shape, test the wiring by replacing the AV85. If the new unit shows GREEN, and the drive still shows encoder loss/tach fault, then the wiring is faulty and should be repaired or replaced.

If the alarm output and/or LED indicate a fault (RED):

1. Remove the rear cover, and use the built-in gauge to check the location of the rotor (see Figure 1). Ensure the label marked "This side out" and/or cam screws is/are facing away from the motor.
2. Remove the AV85 from the motor. Clean the housing mounting surface for the AV85 housing. Ensure the AV85 is directly mounted on the motor, with no sealant, gasketing, or other materials, and is firmly bolted in place.

If the alarm output and/or LED indicate a fault (RED) on a properly mounted AV85 and the rotor is properly located, replace the AV85. An oscilloscope can also be used to verify proper output of the THIN-LINE II encoder at the encoder connector itself and at the drive/controller cabinet. If the outputs show large variations in the signals at steady speed (jitter or "accordion effect", see figure 5), check rotor position. If the rotor position is correct, the motor or shaft may be highly magnetized. Replace any magnetized material nearby with non-magnetic material (aluminum, stainless) (especially shafts). For GE CD frame motors and similar styles, Avtron offers non-magnetic stub shafts. If variations persist, consider replacing the encoder with super-shielded models, option -005, or use retrofit shielding kits AVSKxxx yy z, where xxx=model (ex: 56A), yy=rotor (ex: CB), and z=cover (ex: F).

### NOTE:

**Do not use rotors from THIN-LINE I (M56, M56S, M67, M85, M115) with AV67. This will cause incorrect PPR output, but the AV67 LED will remain green.**

## Encoder Removal

The AV85 stator housing can be removed by loosening and removing the socket head cap screws.

## CAM SCREW AND END-OF-SHAFT ROTOR REMOVAL

Disengage the (2) cam screws or end-of-shaft mounting screw(s) by turning them counterclockwise less than 1 full turn. The cam heads will visibly move away from the shaft. Remove the rotor by hand by pulling it away from the motor. If the rotor will not move, do NOT use a gear puller, and do not use a heat gun. Instead, insert two M6 screws, >25mm length into the Jack Screw Holes shown in Fig 2. Alternately tighten the screws to push the rotor away from the motor and remove it.

End-of-Shaft Spare Parts			
Shaft Size	Option Code	Rotor PN	Hardware provided
1.1250"/1.1245" x 0.40"	EF	AVTR1-EF	3/8"-16 x 1" + roll pin
2.1250"/2.1245" x 0.40"	EN	AVTR1-EN	10-24 x 0.5" (2)
2.3750"/2.3745" x 0.40"	EP	AVTR1-EP	3/8"-16 x 0.88" (2)
2.8750"/2.8745" x 0.40"	E2	AVTR1-E2	3/8"-16 x 0.88" (2)
Shaft Covers			
Shaft Covers	Option Code	PN	Hardware provided
Flat End-of-shaft	F	A36525	10-24 x 0.38" (4)
Extended Shaft (pie-pan cover)	E	A35841	6-32 x 0.31" (4)

## LARGE BORE SET SCREW ROTOR REMOVAL

Disengage the (2) set screws by turning them counterclockwise until removed from the rotor. Retain the set screws. Remove the rotor by hand by pulling it away from the motor. If the rotor will not move, do NOT use a gear puller, and do not use a heat gun. Instead, pry the rotor away from the motor gently, being careful to only pry against the rotor metal hub and not the magnetic outer strip.

CONNECTOR SPARE PARTS					
STYLE	OPTION CODE	ENCODER SIDE		CABLE SIDE PLUG	
Industrial EPIC on Encoder	P,G	315233	Base	315937	Hood
		315229	Terminal	315936	Terminal
Industrial EPIC w/ Adapter Block	Q			401112	Adapter
Industrial EPIC on 3' Cable	Z	315232	Surface	315937	Hood
		315229	Terminal	315936	Terminal
		471819	Bushing	401112	Adapter
Mini-MS Twist Lock	R, S	315296	Base	316110	Plug
10 pin MS on cable	Y	314383	In-Line	315932	Plug
				411216	Cable Bushings
				411217	
				411218	
				411219	
10 pin MS	A, B, C, D	3159331	Base	315932	Plug
				411216	Cable Bushings
				411217	
				411218	
				411219	

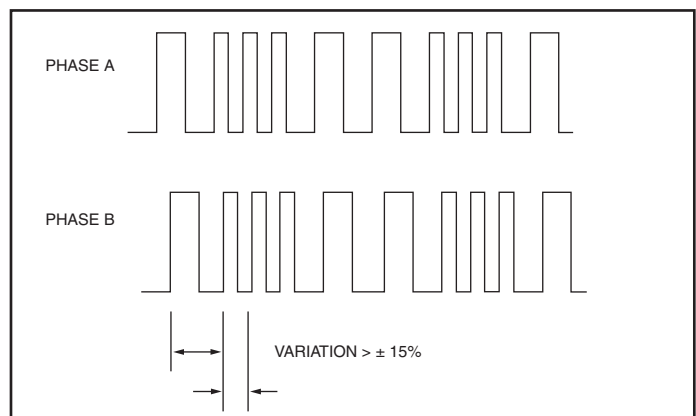

FIGURE 5

FIGURE 1

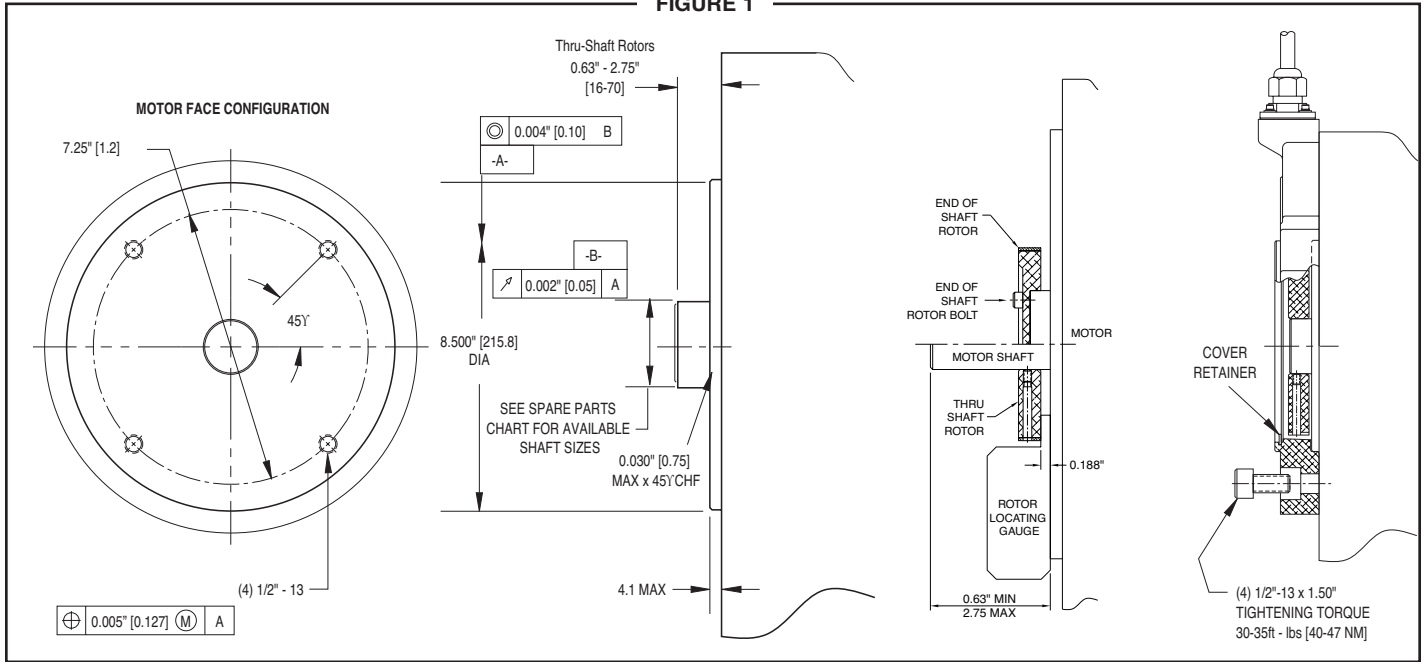

FIGURE 3

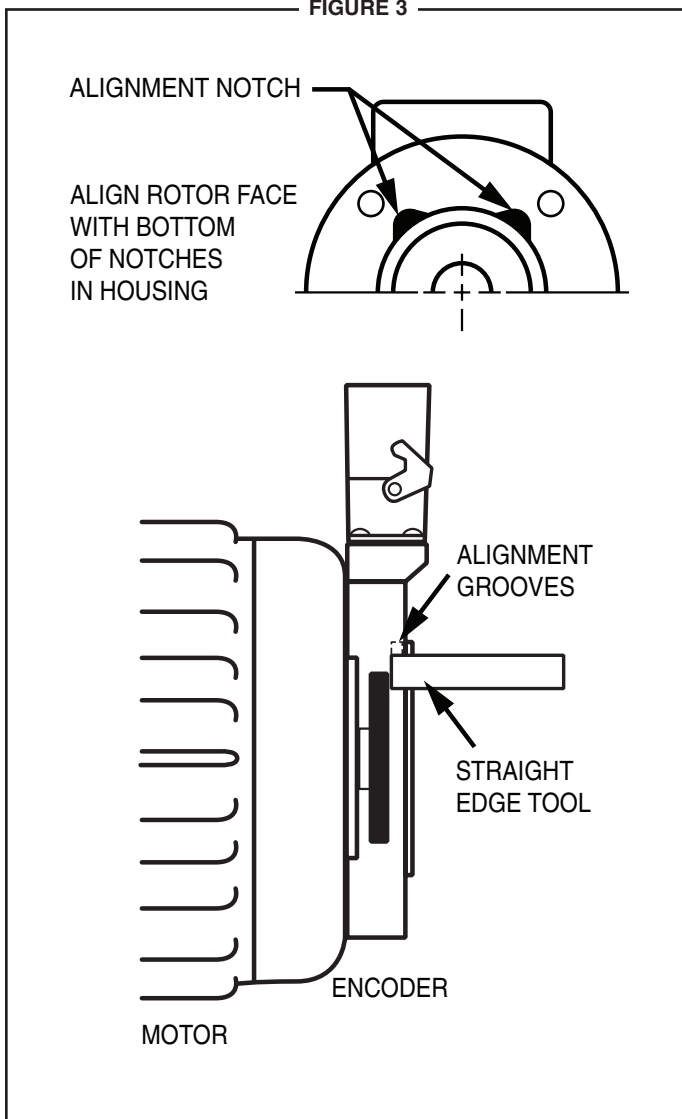
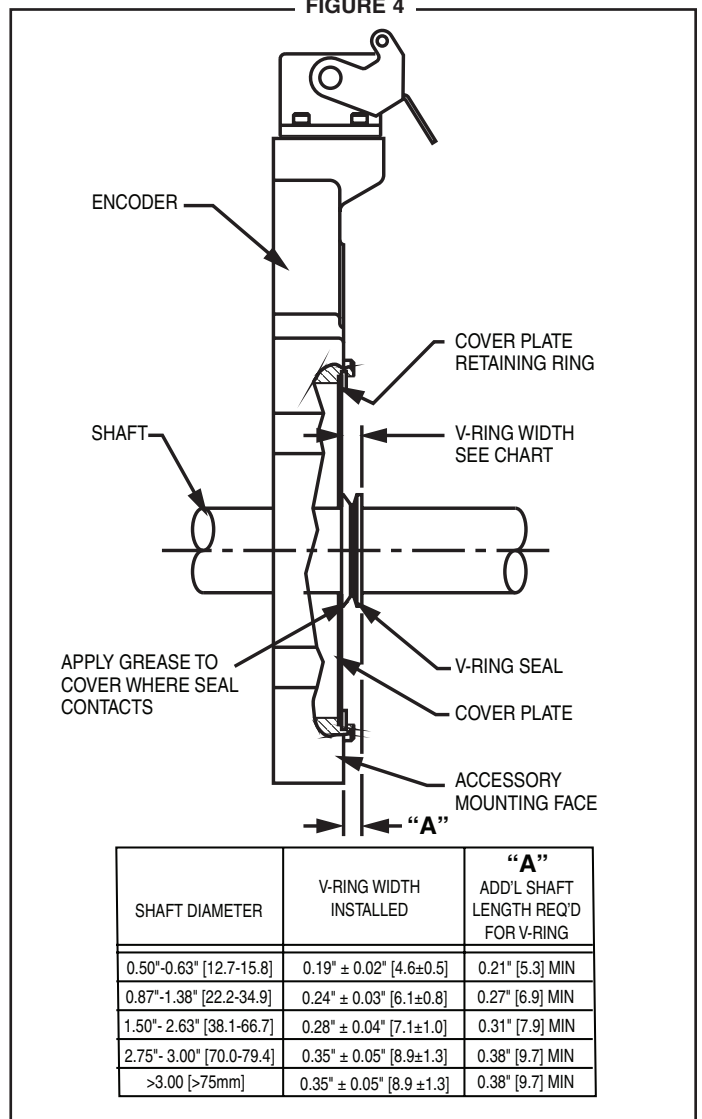

FIGURE 4



## Thinline II Spare Parts (AV56/AV56S/AV67/AV85/AV115 Only)

SAE/USA Sizes

Shaft Size	Rotors AV56A, AV67, AV85, AV115			Rotor AV56S	Thru-Shaft Covers		
	Option Code	Cam Screw	Set Screw	Set Screw Stainless Rotor	AV56, AV56S, AV67 & AV115 Cover Kit	AV85 Cover /kit	Seal Only
.500/.4995	CA	AVTR1-CA	N/A	AVTR2-TA	A36521-TA	A36523-TA	471960
.625/.6245	CB	AVTR1-CB	N/A	AVTR2-TB	A36521-TB	A36523-TB	471877
.875/.8745	CC	AVTR1-CC	N/A	AVTR2-TC	A36521-TC	A36523-TC	471963
.9375/.9370	CD	AVTR1-CD	N/A	AVTR2-TD	A36521-TD	A36523-TD	471963
1.000/.9995	CE	AVTR1-CE	N/A	AVTR2-TE	A36521-TE	A36523-TE	471964
1.125/1.1245	CF	AVTR1-CF	N/A	AVTR2-TF	A36521-TF	A36523-TF	471965
1.250/1.2495	CG	AVTR1-CG	N/A	AVTR2-TG	A36521-TG	A36523-TG	471967
1.375/1.3745	CH	AVTR1-CH	N/A	AVTR2-TH	A36521-TH	A36523-TH	471952
1.500/1.4995	CT	AVTR1-CT	N/A	AVTR2-TT	A36521-TT	A36523-TT	471969
1.625/1.6245	CJ	AVTR1-CJ	N/A	AVTR2-TJ	A36521-TJ	A36523-TJ	471969
1.750/1.7495	CK	AVTR1-CK	N/A	AVTR2-TK	A36521-TK	A36523-TK	471970
1.875/1.8745	CL	AVTR1-CL	N/A	AVTR2-TL	A36521-TL	A36523-TL	471970
2.000/1.9995	CM	AVTR1-CM	N/A	AVTR2-TM	A36521-TM	A36523-TM	471971
2.125/2.1245	CN	AVTR1-CN	N/A	AVTR2-TN	A36521-TN	A36523-TN	471972
2.250/2.2495	CQ	AVTR1-CQ	N/A	AVTR2-TQ	A36521-TQ	A36523-TQ	471972
2.375/2.3745	CP	AVTR1-CP	N/A	AVTR2-TP	A36521-TP	A36523-TP	471953
2.500/2.4995	CR	AVTR1-CR	N/A	AVTR2-TR	A36521-TR	A36523-TR	471954
2.625/2.6245	TS	N/A	AVTR1-TS	AVTR2-TS	A36521-TS	A36523-TS	471954
2.875/2.8745	TU	N/A	AVTR1-TU	AVTR2-TU	A36521-TU	A36523-TU	471956
3.000/2.9995	TV	N/A	AVTR1-TV	AVTR2-TV	A36521-TV	A36523-TV	471956
3.1250/3.1245	T4	N/A	AVTR1-T4	AVTR2-T4	A36737-T4	A36523-T4	471957
3.1875/3.1870	T7	N/A	AVTR1-T7	AVTR2-T7	A36737-T7	A36523-T7	471957

1.125" w/.25" Keyway	B33334-2	B29787
15/16" w/.25" Keyway	B33334-1	B31033

### Extended and Flat Cover Plates

Shaft Size	Model	Extended Shaft Cover Kit	Flat Cover Kit
Any	AV56A, AV67, AV115	A35841	A37298
Any	AV56S	A36526	A37298
Any	AV85	A35841	A36525

## Thinline II Spare Parts (AV56/AV56S/AV67/AV85/AV115 Only)

### Metric Sizes

Shaft Size	Rotors AV56A, AV67, AV85, AV115			Thru-Shaft Covers		
	Option Code	Cam Screw	Set Screw	AV56, AV56S, AV67 & AV115 Cover Kit	AV85 Cover /kit	Seal Only
10mm	D2	AVTR1-D2	N/A	A36522-M2	A36524-M2	471959
11mm	DA	AVTR1-DA	N/A	A36522-MA	A36524-MA	471959
12mm	D3	AVTR1-D3	N/A	A36522-M3	A36524-M3	471960
14mm	DB	AVTR1-DB	N/A	A36522-MB	A36524-MB	471961
15mm	DC	AVTR1-DC	N/A	A36522-MC	A36524-MC	471961
16mm	DD	AVTR1-DD	N/A	A36522-MD	A36524-MD	471877
18mm	D4	AVTR1-D4	N/A	A36522-M4	A36524-M4	471962
19mm	DE	AVTR1-DE	N/A	A36522-ME	A36524-ME	471951
24mm	DF	AVTR1-DF	N/A	A36522-MF	A36524-MF	471964
28mm	DG	AVTR1-DG	N/A	A36522-MG	A36524-MG	471965
30mm	DH	AVTR1-DH	N/A	A36522-MH	A36524-MH	471966
32mm	DT	AVTR1-DT	N/A	A36522-MT	A36524-MT	471967
36mm	DJ	AVTR1-DJ	N/A	A36522-MJ	A36524-MJ	471968
38mm	DK	AVTR1-DK	N/A	A36522-MK	A36524-MK	471969
42mm	DL	AVTR1-DL	N/A	A36522-ML	A36524-ML	471969
45mm	DM	AVTR1-DM	N/A	A36522-MM	A36524-MM	471970
48mm	DN	AVTR1-DN	N/A	A36522-MN	A36524-MN	471971
52mm	DP	AVTR1-DP	N/A	A36522-MP	A36524-MP	471971
55mm	DR	AVTR1-DR	N/A	A36522-MR	A36524-MR	471972
60mm	DS	AVTR1-DS	N/A	A36522-MS	A36524-MS	471953
65mm	MU	N/A	AVTR1-MU	A36522-MU	A36524-MU	471954
70mm	MV	N/A	AVTR1-MV	A36522-MV	A36524-MV	471955
75mm	MW	N/A	AVTR1-MW	A36522-MW	A36524-MW	471956
80mm	MY	N/A	AVTR1-MY	A36737-MY	A36524-MY	471957
85mm	MZ	N/A	AVTR1-MZ	A36737-MZ	A36524-MZ	471958

### Extended and Flat Cover Plates

Shaft Size	Model	Extended Shaft Cover Kit	Flat Cover Kit
Any	AV56A, AV67, AV115	A35841	A37298
Any	AV56S	A36526	A37298
Any	AV85	A35841	A36525

# WIRING DIAGRAMS

## FOR DIFFERENTIAL APPLICATIONS

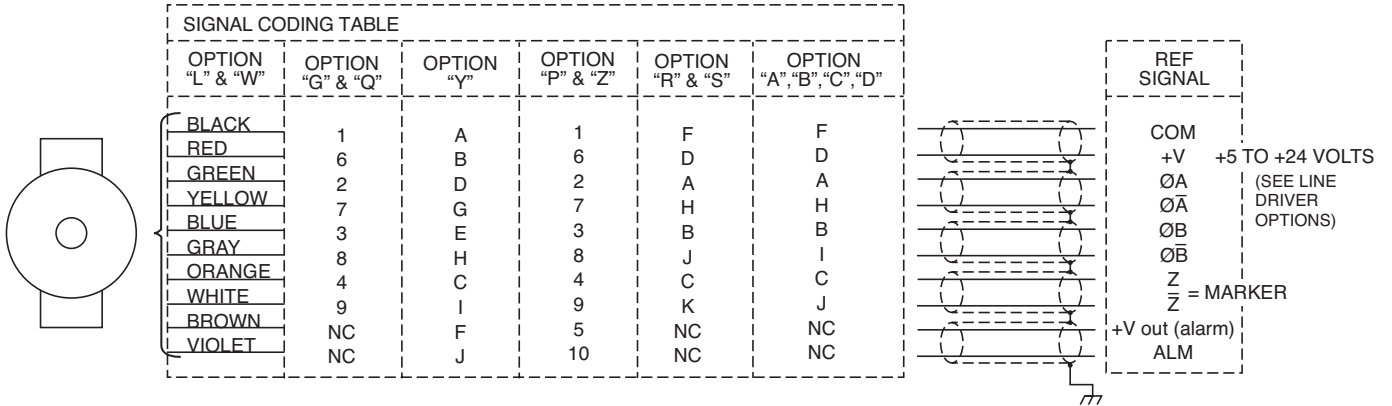

## FOR SINGLE ENDED TWO PHASE APPLICATIONS

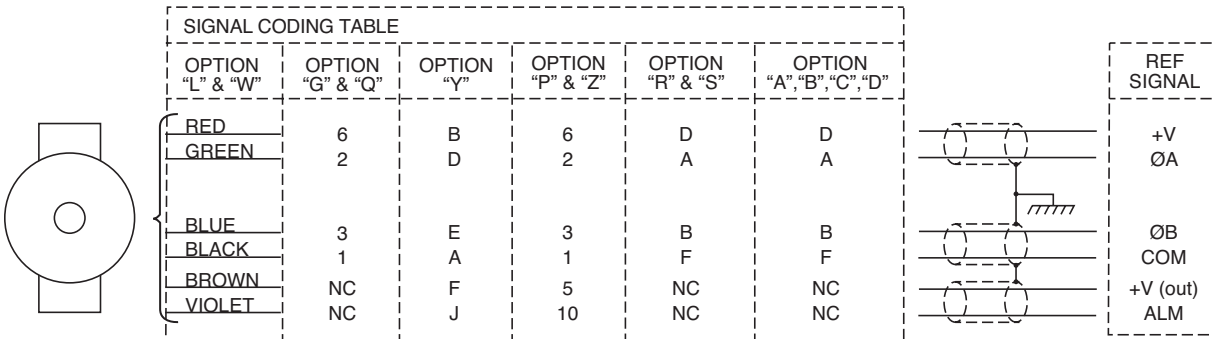

## FOR SINGLE ENDED SINGLE PHASE APPLICATIONS

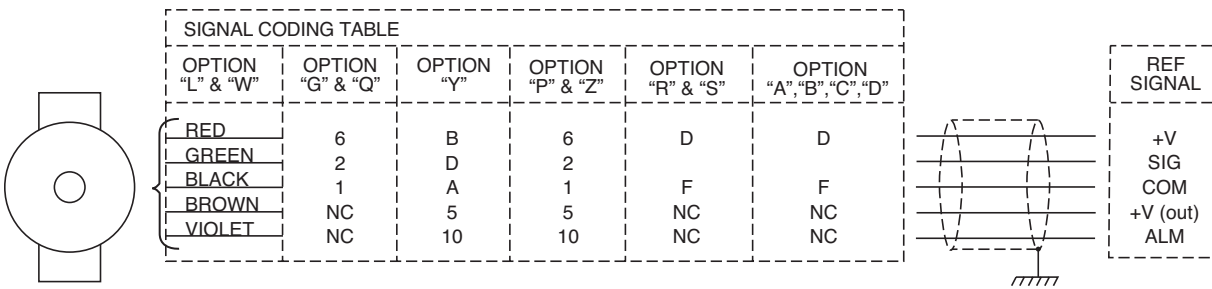

**TYPICAL WIRE SELECTION CHART**  
for 18 AWG, multiple pair, individually shielded

	BELDEN	ALPHA
2 PAIR	9368	5620B1802
3 PAIR	9773 or 9369	6445
4 PAIR	9388	6444
3 CONDUCTOR	9365	5640B1801

For option "W", unused outputs must be insulated to prevent accidental contact.

**NOTE:** Avtron standard 3 year warranty applies. Copies available upon request. Specifications subject to change without notice.



# THIN-LINE II™

## Application Examples

Applies to all AV85 models, except, wiring options "A", "B", "C", "D", "G", "Q", "R", "S", "T" and "U".

### ALARM OUTPUT CONNECTION

Avtron THIN-LINE II encoders provide an alarm signal if maintenance is required under specific circumstances. An alarm LED indicator is also available. Green indicates power on, red indicates alarm on. Following are application examples provided to help install the alarm output.

Example 1. Alarm output using +V(OUT). +V(OUT) is equal to +V, the encoder power supply.

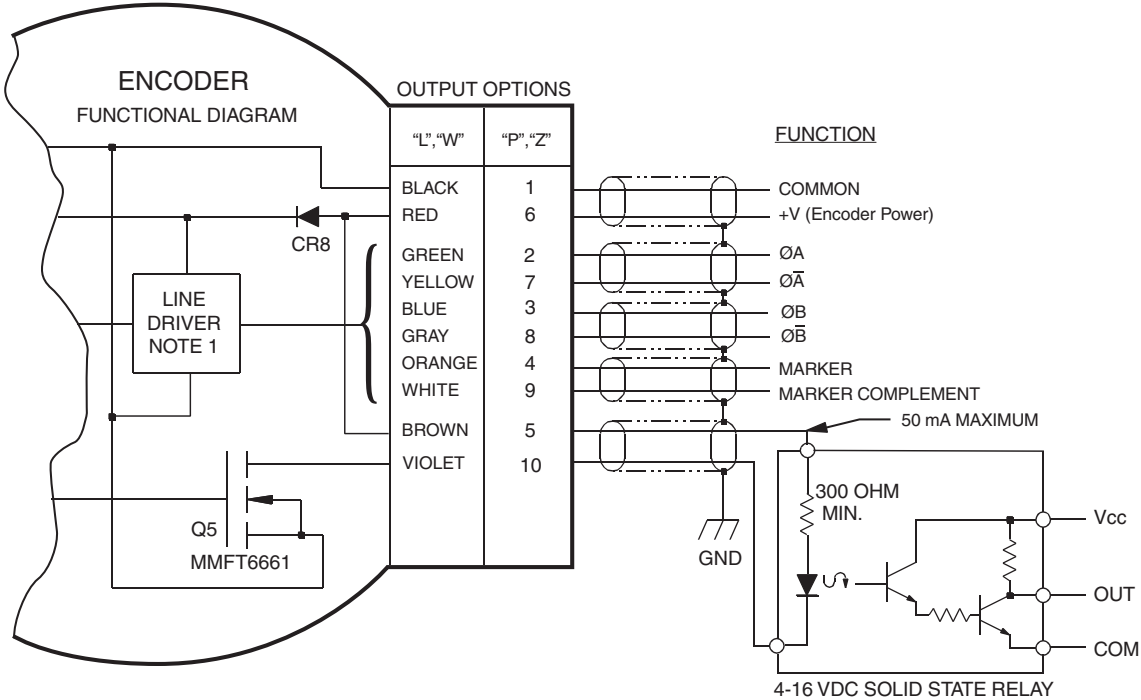

Example 2. Alarm Output Using Separate 24 VDC Power Supply and Relay.

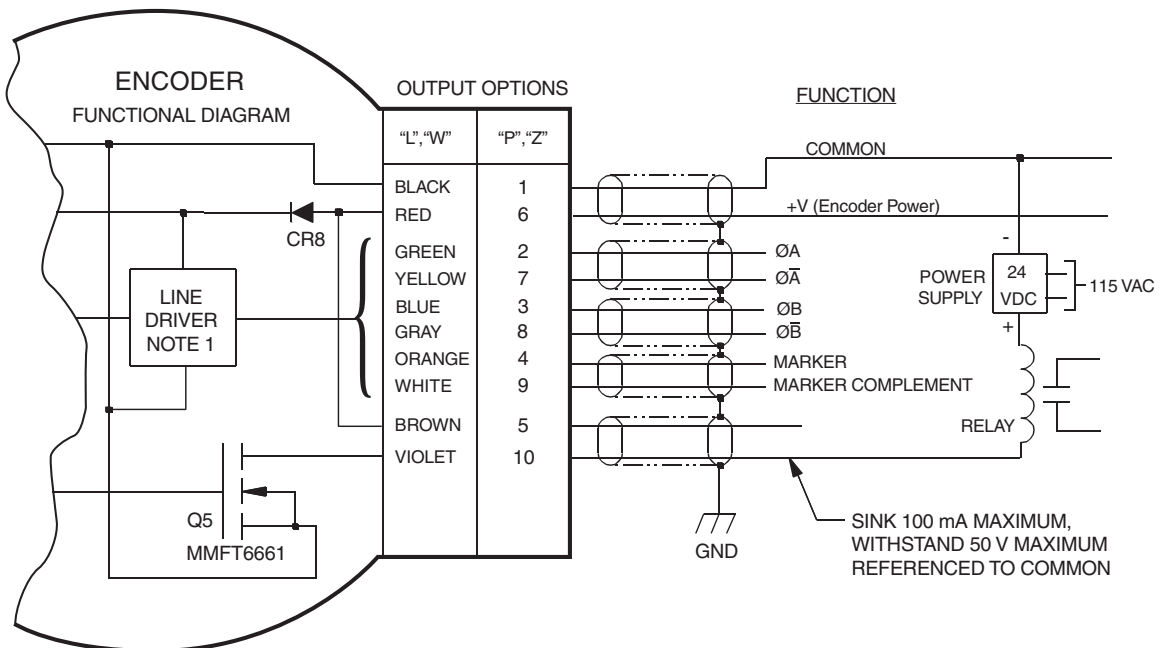

# OUTLINE DRAWING

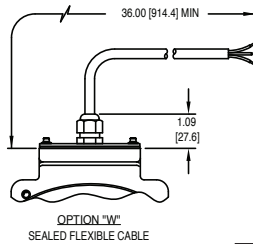
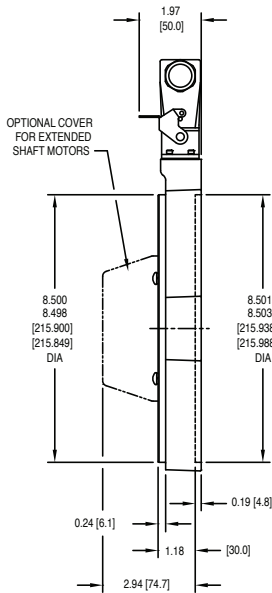
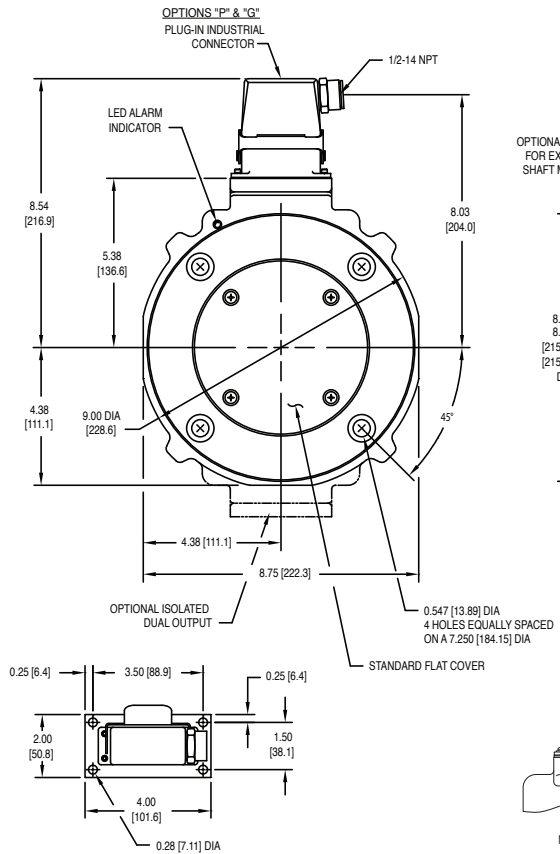

## Maximum Shaft Length

Cover	Length
F	0.69 [17.5]
D	0.96 [24.3]
E	2.50 [63.5]
T	Unlimited

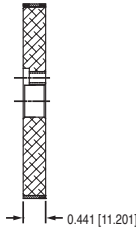
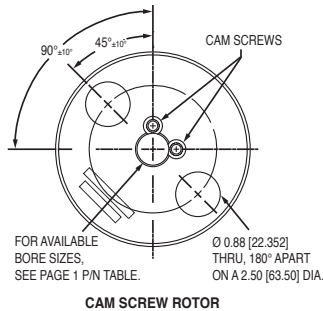
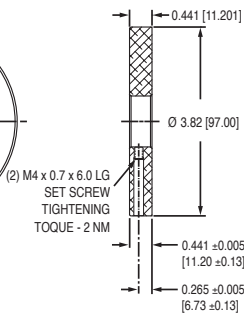
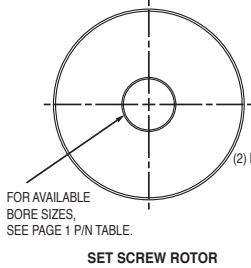
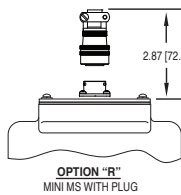
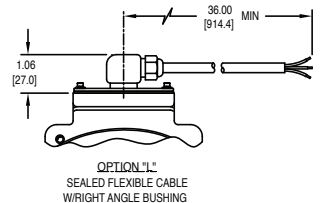
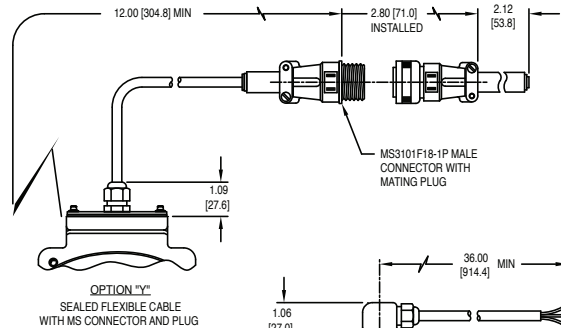
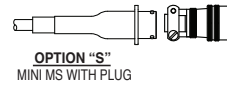

- 3 - DIMENSIONS IN INCHES [MILLIMETERS]
  - 2 - ALL DIMENSIONS ARE APPROXIMATE
  - 1 - WEIGHT: 2.5 - 4LBS [1.13 TO 1.81 KG].
- NOTES:



CE Pending  
 Features and specifications subject to change without notice.  
 Avtron standard warranty applies. All dimensions are in millimeters approx.

Nidec-Avtron Makes the Most Reliable Encoders in the World  
 8901 E. PLEASANT VALLEY ROAD • INDEPENDENCE, OHIO 44131-5508  
 TELEPHONE: (1) 216-642-1230 • FAX: (1) 216-642-6037  
 E-MAIL: tachs@nidec-avtron.com • WEB: www.avtronencoders.com