

# Avtron AV56 THIN-LINE III™ Encoders



## Heavy Mill Duty Magnetic Modular Encoder 4.5" C-Face Mount

### STRONGER and SMARTER

- | Heavy Mill Duty
- | Simple, Secure Installation
- | All models are protected against all short circuits and wiring errors
- | Wide-Gap Technology: No Sensor Scraping or Adjustment
  - | Up to 50000 PPR
  - | No Couplings or Bearings
  - | Sealed Electronics
- | Self-Diagnostic LED and Alarm Output
  - | Universal 5-24V Operation
  - | 3 Year No-Hassle Warranty

### AV56

AV56 THIN-LINE III™ heavy mill duty modular magnetic encoders fit standard 4.5" C-Face motors such as Marathon Blue and Black Max, as well as Baldor Reliance models. The stainless steel AV56S is designed for washdown and marine duty. Other THIN-LINE III models, ranging from 115mm to 8.5", are available to fit other motor sizes.

THIN-LINE III encoders feature simple installation, durable construction, and clear diagnostics to eliminate encoder-related downtime:

First, the magnetic sensors are fully potted, to withstand dirt and liquids. No glass disks, no optics to clog. There are no moving, wearing parts!

The patented Wide-Gap™ Cam Screw Rotors™ put an end to sensor damage, are simpler to install, and stay securely mounted to the shaft.

The universal 5-24V design drives longer cables and is protected against wiring errors and surges.

When you power up an AV56, you know you installed it right: the green LED tells you the digital self-tuning has set your AV56 optimally.

If at any time, the AV56 cannot produce ideal signals, the LED changes to red and the remote alarm contact activates. Even wiring errors and short circuits are detected and indicated by changing the LED to orange. However, the encoder keeps working to give you time to schedule service.

With a real-world installation history of over 4,500,000 hour MTBF, AV56 encoders will keep your machine running 24/7/365!

# OUTLINE DRAWING

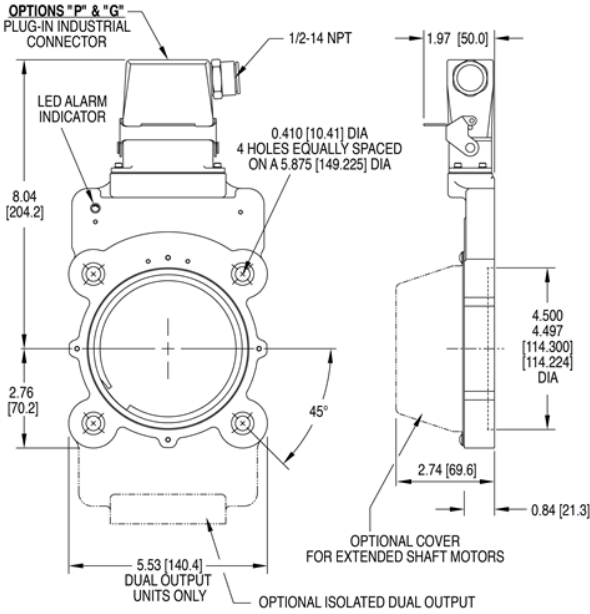

# MORE AV56 ADVANTAGES

- Replaces Avtron M56, Northstar/Dynapar™ D5, D560, SL56, ST56, Wind56; online cross reference guide available
- Shrugs off dirt, oil, and water contamination
- Highly resistant to electrical and magnetic motor and brake noise
- If damaged, electronics can be replaced without removing rotor
- Patented Cam Screw Rotor™ eliminates rotor slipping
- Built-in motor position guide and diagnostic check
- No air gap adjustment required
- Sealed thru-shaft option
- Fits shafts 0.500" - 3.188" [10 - 85 mm]
- 4,500,000+ hour MTBF design

# AV56 SPECIFICATIONS

**Operating Power:** Volts: 5 - 24 VDC; Current: 100mA, no load  
**Output Format:** A Quad B with Marker (A,A-, B,B-, Z,Z-)  
**Second Isolated Output:** Optional  
**Frequency Range:** @5V, @1m cable, 250 kHz Max  
 @24V, @300m cable, #8 output, 45 kHz Max  
**Maximum Cable Length:** 1000'  
**PPR:** 4 - 50000  
**Speed:** 5400 RPM Max. std., for higher speeds, consult factory  
**Electronics:** Fully Encapsulated, IP67 (see manual for details)  
**Temperature:** -40° to 100°C (150°C rotor)  
**Vibration:** 18 g's  
**Shock:** 1 meter drop test  
**Chemical:** Polyurethane enamel paint protects against salt spray, mild acids, and bases.  
**Weight:** 2 - 3 lbs [0.9 - 1.36 kg]

Check out our website for more detailed specifications, drawings, and installation instructions. [www.avtronencoders.com](http://www.avtronencoders.com)

All dimensions are in inches [millimeters]; Specifications and features are subject to change without notice.

# SELECTION GUIDE

Model	Housing Type	Shaft Size (Thru Shaft Rotor)	Cover Style	Line Driver	Single/Left Output (PPR)	Right Output (PPR)	Connector	Modifications
AV56A	1- Single Output 2- Dual Output	C0- Non-std. Shaft Size XX- None  Thru Shaft Rotor US Metric CA- 0.500 D2- 10mm CB- 0.625 DA- 11mm CC- 0.875 D9- 12mm CD- 0.938 DB- 14mm CE- 1.000 DC- 15mm CF- 1.125 DD- 16mm CG- 1.250 DA- 18mm CH- 1.375 DE- 19mm CT- 1.500 DF- 24mm CJ- 1.625 DG- 28mm CK- 1.750 DH- 30mm CL- 1.875 DT- 32mm CM- 2.000 DJ- 35mm CN- 2.125 DK- 38mm CQ- 2.250 DL- 42mm CP- 2.375 DM- 45mm CR- 2.500 DN- 48mm TS- 2.625 DP- 52mm TU- 2.875 DR- 55mm TW- 2.750 DS- 60mm TV- 3.000 MU- 85mm* TA- 3.125 MV- 70mm* TT- 3.188 MW- 75mm* TZ- 3.250 MY- 80mm* MZ- 85mm*	E- Extended Shaft Cover F- Flat Cover T- Flat Thru-Hole Cover with Shaft Seal. D- Dome Cover	6- 5-24V in/out 8- 5-24 V in, 5-24 V out 9- 5-24V in, high power 5V out	0- Non-std. J- 960 F- 60 Y- 1024 G- 100 Z- 1200 H- 120 3- 2000 A- 128 4- 2048 L- 240 5- 2500 N- 256 D- 4096 P- 300 8- 4800 E- 360 9- 5000 B- 480 Q- 500 R- 512 S- 600 V- 900	0- Non-Std. W- 1000 F- 60 Y- 1024 G- 100 Z- 1200 H- 120 3- 2000 A- 128 4- 2048 L- 240 5- 2500 N- 256 D- 4096 P- 300 8- 4800 E- 360 9- 5000 B- 480 Q- 500 R- 512 S- 600 V- 900	W- 3Ft Cable Sealed	000-No Modification 004-Add Housing Drain (single output only) 005-Super Magnetic Shielding 4xx-Special PPR Enter Ø in the PPR code(s), select the special option code below 9xx-Special Cable Length, xx=length in feet 00W- Connector on 18" cable: Use w/ options "T", "U"

\* Set Screw Rotor Only .

\*\* Not applicable on dual output.  
\* No insert used for Options "F", "G", "Y", "3".

Connector Options							
Mounted on Encoder				Mounted on 18" cable			00W
10 Pin MS	10 Pin EPIC	10 Pin mini MS	7 Pin MS	10 Pin MS	10 Pin EPIC	10 Pin mini MS	(*8 Pin M12
A- w/o plug (std. phasing) B- w/o plug (Dynapar HS35 phasing) C- "A" w/ plug D- "B" w/ plug	G- w/ plug Northstar pinout P- w/ plug	R- w/ plug	J- w/o plug	Y- 12" cable w/o plug on conduit box (Large encoder pinout)	Q- 18" Cable w/o plug on remote mount blade Z- 36" Cable w/ plug	S- 18" Cable w/ plug	T- w/o plug (Turck Pinout) U- w/o plug (US Pinout)

(\*)Requires Special option 00W



Nidec-Avtron Makes the Most Reliable Encoders in the World  
 8901 E. PLEASANT VALLEY ROAD • INDEPENDENCE, OHIO 44131-5508  
 TELEPHONE: (1) 216-642-1230 • FAX: (1) 216-642-6037  
 E-MAIL: [tachs@nidec-avtron.com](mailto:tachs@nidec-avtron.com) • WEB: [www.avtronencoders.com](http://www.avtronencoders.com)

All dimensions are in inches [millimeters]. Specifications and features are subject to change without notice. EU-SMART™, SMARTSafe™, SMARTach II™, THIN-LINE™, THIN-LINE II™, WIDE-GAP™, and BULLSEYE32™ are trademarks of Nidec Avtron Automation. All other trademarks and registered trademarks are the property of their respective owners.