



Nidec-Avtron Makes the Most Reliable Encoders in the World

8901 E. PLEASANT VALLEY ROAD • INDEPENDENCE, OHIO 44131-5508

TELEPHONE: (1) 216-642-1230 • FAX: (1) 216-642-6037

E-MAIL: tachs@nidec-avtron.com • WEB: www.avtronencoders.com

Encoder Instructions

MODEL AV56A

4 1/2" C-FACE MOUNT MODULAR

DESCRIPTION

The Avtron AV56A is a modular, two piece incremental encoder (also known as a tachometer or rotary pulse generator). It provides a two phase, A Quad B frequency (pulse) output, with complements. The AV56A mounts on a 4.5" (NEMA 56C) Face.

Because the AV56A is modular, there are no bearings or couplings required. This, combined with the latest magneto-resistive (MR) sensor technology, allows the AV56A to provide superior mechanical performance and increased reliability.

An Avtron AV56A can be configured with one or two independent outputs. Each output has six signals: (A, B) 90° out of phase, with complements (\bar{A} , \bar{B}). A marker pulse with complement (Z, \bar{Z}) is also provided.

Output resolution on the AV56A is determined by the sensor only. Unlike older models, any PPRs can be mixed and matched. Selection of the rotor is based only on the shaft mounting requirements (and not PPR).

Equipment Needed for Installation

Provided	Optional	Not Provided
AV56A Stator/Housing Socket Hd Cap Screw 3/8"-16 x 1.25" (4) AV56A Rotor Socket Set Screw M4 x 8mm (2) or Pre-Installed Cam Screw Thread locker (blue)	Extended Shaft Cover [or Dome Shaft Cover] w/ Screws 6-32 x 0.31" (4) Lock Washers Thru Shaft Cover w/ V-Ring Seal and Silicone Lubricant	Phillips Screwdriver 2mm Hex Wrench (T-Handle Style for Thru-Shaft Rotors >70mm) 3mm Hex Wrench 5/16" Hex Wrench

Model	Housing Type	Shaft Size (Thru Shaft Rotor)	Cover Style	Line Driver	Single/Left Output (PPR)	Right Output (PPR)	Connector	Modifications
AV56A	1- Single Output 2- Dual Output	C0- Non-std. Shaft Size XX- None Thru Shaft Rotor US Metric CA- 0.500 D2- 10mm CB- 0.625 DA- 11mm CC- 0.875 D3- 12mm CD- 0.938 DB- 14mm CE- 1.000 DC- 15mm CF- 1.125 DD- 16mm CG- 1.250 D4- 18mm CH- 1.375 DE- 19mm CT- 1.500 DF- 24mm CJ- 1.625 DG- 28mm CK- 1.750 DH- 30mm CL- 1.875 DT- 32mm CM- 2.000 DJ- 36mm CN- 2.125 DK- 38mm CQ- 2.250 DL- 42mm CP- 2.375 DM- 45mm CR- 2.500 DN- 48mm TS- 2.625* DP- 52mm TU- 2.875* DR- 55mm TW- 2.750* DS- 60mm TV- 3.000* MU- 65mm* T4- 3.125* MV- 70mm* T7- 3.188* MW- 75mm* TZ- 3.250* MY- 80mm* MZ- 85mm*	E- Extended Shaft Cover F- Flat Cover T- Flat Thru-Hole Cover with Shaft Seal. D- Dome Cover	6- 5-24V in/out 8- 5-24 V in, 5-24 V out high power 9- 5-24V in, 5V out	0- Non-std. W- 1000 J- 960 Y- 1024 K- 1024 Z- 1200 L- 2000 3- 2000 A- 128 4- 2048 M- 240 5- 2500 N- 256 D- 4096 P- 300 8- 4800 E- 360 9- 5000 B- 480 Q- 500 R- 512 S- 600 V- 900	0- Non-std. W- 1000 J- 960 Y- 1024 K- 1024 Z- 1200 L- 2000 3- 2000 A- 128 4- 2048 M- 240 5- 2500 N- 256 D- 4096 P- 300 8- 4800 E- 360 9- 5000 B- 480 Q- 500 R- 512 S- 600 V- 900	W- 3Ft Cable Sealed	000- No Modification 004- Add Housing Drain (single output only) 005- Super Magnetic Shielding 4xx- Special PPR Enter Ø in the PPR code(s), select the special option code below 9xx- Special Cable Length, xx=length in feet

* Set Screw Rotor Only .

** Not applicable on dual output.
* No insert used for Options "F", "G", "Y", "3".

Connector Options

Mounted on Encoder				Mounted on 18" cable		
10 Pin MS	10 Pin EPIC	10 Pin mini MS	7 Pin MS [«]	10 Pin MS [«]	10 Pin EPIC [«]	10 Pin mini MS [«]
A- w/o plug (std. phasing) B- w/o plug (Dynapar HS35 phasing) C- "A" w/ plug D- "B" w/ plug	G- w/ plug Northstar pinout P- w/ plug	R- w/ plug	J- w/o plug	Y- 12" cable w/o plug on conduit box (Large encoder pinout)	Q- 18" Cable w/o plug on remote mount blade Z- 36" Cable w/ plug	S- 18" Cable w/ plug

SPECIAL PPR OPTION CODES

OPTION CODE	LEFT PPR	RIGHT PPR
401	1270	None
402	150	None
403	50	None
404	512	16
405	16	None
406	6000	None
407	2800	None
408	1400	None
409	30	None
410	None	6000

NOTE
THIN-LINE III™ directly replaces **THIN-LINE II™** and **THIN-LINE™** models. **THIN-LINE III** models have **Rev Code BA or later**. **Special option 4xx** selects an alternate **PPR code definition**. **Example: PPR Code 0, Special Option Code 401 = 1270 PPR (Left), No Right Output.**

INSTALLATION

Installation and removal videos for the AV56A/67/85/115 are available on Avtron's web site. Refer to the back page of these instructions for outline and mounting dimensions. The motor must comply with 1998 NEMA MG 1, section 4, for tolerances on diameters and runout for shafts and accessory faces. Axial float or endplay must be less than ±0.050".

In preparation for installing the Model AV56A encoder, it is first necessary to clean both the accessory motor shaft and the mounting face. These surfaces must be inspected and any paint, burrs, or other surface imperfections removed.

Installation procedures should be performed only by qualified personnel. Safety precautions must be taken to ensure machinery cannot rotate and all sources of power are removed during installation.

ROTOR INSTALLATION

The motor shaft must project at least 0.63" from the motor face. For set screw rotors only: Apply anti-seize compound to the motor shaft. For all rotors: Slide the rotor onto the shaft with the marking "Motor side" facing in, (toward the motor face). The rotor centerline must match the sensor centerline. To accomplish this, use the rotor locating gauge (A28503) and slide the rotor onto the shaft until it is in the proper position as shown in Figure 1. If a gauge is not available, use the stator housing alignment grooves as shown in Figure 3.

STANDARD CAM SCREW ROTOR INSTALLATION

Turn the cam screws of the rotor in the directions shown on the rotor to engage the cams. Tighten to 50-60 in-lb [5.6 - 6.8 N-m] (See Figure 2) using the 3mm hex wrench. Total cam screw rotation will be less than one turn.

CAUTION

Do not adjust the cam screws before motor shaft mounting; bottoming out the screws, or backing them out excessively, can lead to insufficient shaft holding force. Thread locker is preapplied on the cam screws.

LARGE BORE SET SCREW ROTOR INSTALLATION

Apply thread locker to the rotor set screw holes, preferably from the inside of the rotor bore before mounting. Tighten the rotor set screws to 15 in-lb [2 N-m] using the 2mm T-handle hex wrench.

CAUTION

Use only a T-handle or torque hex wrench to tighten set screws; using a right angle wrench will not provide enough holding force, and the rotor may slip.

STATOR HOUSING INSTALLATION

The stator housing is attached to the motor using four socket head cap screws (4) 3/8"-16, locating on a 5.88" bolt circle. Longer bolts (not included), are required for sandwich installation between a motor and a brake. Install the four mounting bolts using thread locker and torque to approximately 20-30 ft lbs [27 to 40 N-m] using the 5/16" T-handle hex wrench.

SPECIFICATIONS

ELECTRICAL

- A. Operating Power (Vin)
 - 1. Volts.....5-24 VDC
 - 2. Current80mA, each output, no load
- B. Output Format
 - 1. 2Ø & CompA,Ā, B,Ī (differential line driver)
 - 2. Marker1/Rev, Z, Z̄
- C. Signal TypeIncremental, Square Wave, 50 ±10% Duty Cycle.
- D. Direction SensingØ A leads Ø B for CW rotation as viewed from the back of the tach looking at the non-drive end of the motor.
- E. Phase Sep.15% minimum
- F. Frequency Range@5V, @1m cable, 250 kHz Max
 @24V, @300m cable, #8 output, 45 kHz Max
- G. PPR4-50000
- H. Line Driver SpecsSee table
- I. ConnectorsSee connector options on page 1
- J. Integral LED Indicator ..GREEN: power on, unit ok. RED: alarm on
 ORANGE: wiring fault

MECHANICAL

- A. Rotor Inertia:.....0.17-0.36 Oz. In. Sec.²
- B. Acceleration:.....5000 RPM/Sec. Max.
- C. Speed:.....5400 RPM Max.
- D. Weight:.....2-3 lbs [0.9kg to 1.36kg].
- E. Sensor to Rotor
 - Air Gap (nominal):.....0.021" [0.58mm]
 - Tolerance:0.015" [0.38mm]
- F. Rotor Axial Tolerance.±0.050" [±1.27mm]

ENVIRONMENTAL

Solid cast aluminum stator and rotor
 Fully potted electronics, protected against oil and water spray
 Use "W" cable option on IP66/67 applications
 V-Ring seals provided on through shaft covers
 Operating Temperature:.....-40 to 100°C, 0-100% condensing humidity
 Vibration: 18 g's
 Shock: 1 meter drop test

LINE DRIVER OPTIONS

Electrical Specifications		LINE DRIVER OPTIONS			Units
		6	8	9	
Input Voltage		5-24	5-24	5-24	VDC
Nom Output Voltage		5-24	5-24	5	VDC
Line Driver		7272	Hx	7272	
Output Resistance Typ		13	75	13	ohms
Maximum Peak Current		1500	3000	1500	mA
Maximum Average Current		120	250	120	mA
Voh Typ		VIN-1	VIN-1	VIN-1	VDC
Vol Typ		0.5	0.2 @ 10mA line current	0.5	VDC
Cable Drive Capacity		1000' @ 5V 500' @ 12V 200' @ 24V	1000'	1000'	feet
Protection	Reverse Voltage	yes	yes	yes	
	Short Circuit	yes	yes	yes	
	Transient	yes	yes	yes	
	Power to A, Gnd to A/	yes	yes	yes	
Alarm	+V(out)	Output voltage equal to input voltage.			
	Alarm*	Open collector, normally off, goes low on alarm, sink 100mA max, 50VDC max			
	LED	Green=power on, Red=Alarm, Orange=Wiring Error			
Marker		One per revolution. Pulse width approximately 2°			

*Alarm not available on connector option "G" (Northstar™ compatible pinout)
 ** Electrical specifications for THIN-LINE III model (rev BA or later), consult Nidec Avtron for earlier model specifications.

VERIFY ROTOR LOCATION

To ensure the rotor is properly located on the shaft: remove the back cover if factory-preinstalled, and verify that the outer face of the rotor is at the same depth as the alignment grooves, using a straight edge tool. (Figure 3)

CAUTION

Do not use silicone sealants or caulk of any kind on the motor or encoder face; these can cause misalignment or sensor scraping damage. The AV56A electronics are fully sealed; water may enter and leave the rotor area as needed. A drain hole option is available if frequent moisture buildup is expected.

COVER INSTALLATION

Covers must not interfere with the motor shaft or rotor. The longest shaft that can be used without interfering is 0.69" [17.5mm] with a standard flat cover (Cover Style option "F") 0.96" [24.3mm] with Dome Cover Option "D" and 2.5" [63.5mm] with an extended "pie pan" cover (Cover Style option "E"). Through shaft covers with seals are available for other applications (Cover Style option "T").

EXTENDED COVER MOUNT

(Cover Style option "E")

The extended cover mounts to the encoder housing using quantity 4 #6-32 x 0.31" screws, lock washers, and thread locker.

THRU SHAFT AND FLAT COVER INSTALLATION

(Cover Style option "T" and "F")

The housing has a machined step in the outboard face to accept the cover and a recessed groove for the retaining ring. Insert the cover, line up ears on cover, smooth side facing out, fully into the machined step until it seats against shoulder. Using a spiral assembly method, install the retaining ring by first inserting the squared off end into the machined groove. Flex the ring and insert it into the groove walking it around the perimeter (A flat blade screwdriver can be used). Final position should have the ring fully seated into groove. Remove the cover by reversing above procedure, starting with the tang end.

V-RING INSTALLATION FOR THRU SHAFT COVERS

(Cover Style option "T")

For thru shaft covers, verify that the shaft passes completely through the hole in the cover. Apply a small amount of silicone lubricant to the cover plate around the thru shaft hole. The V-Ring seal should compress axially when it is pressed against the clean, smooth face of the cover plate. See Figure 4 for proper installation and V-Ring compression.

WIRING

Caution

Be sure to remove power before wiring the encoder. Be sure to ground the cable shield: It can be connected to case ground at the encoder, or grounded as the receiving device, but should not be grounded on both ends. See note below for Danaher/Northstar wiring.

Refer to the wiring diagrams for specific information on each option.

The AV56A can be wired for single phase or two phase, either with or without complements, with or without markers. For bidirectional operation, Phase A channel leads phase B channel for clockwise shaft rotation as viewed from the anti-drive or accessory end of the motor (AV56A mounting end).

NOTE

Wiring option "G" provides a pinout compatible with Northstar™ encoders, with a cable shield connection on pin 10. Note that this option does not ground the shield; Avtron still recommends grounding the shield at the drive end of the cable for all wiring options.

CORRECTIVE ACTION FOR PHASE REVERSAL

- 1) Remove Power.
- 2) Exchange wires on cable, either at encoder cable end, or at speed controller end (but not both).
 - a) Single Ended 2 Phase Wiring (see wiring diagram) Exchange A and B at the use end of the wires.
 - b) Differential 2 Phase Wiring (see wiring diagram) Exchange either A with \bar{A} in the phase A pair OR B with \bar{B} in the phase B pair but NOT both.
- 3) Apply Power.
- 4) Verify encoder feedback is correct, using hand rotation of shaft, or jog mode of the speed controller.

Interconnecting cables specified in the wire selection chart are based on typical applications. Physical properties of cable such as abrasion, temperature, tensile strength, solvents, etc., are dictated by the specific application. General electrical requirements are: stranded copper, 22 through 16 AWG (Industrial EPIC connector type options can use 14 AWG), each wire pair individually shielded with braid or foil with drain wire, .05 uf of maximum total mutual or direct capacitance, outer sheath insulator. See specifications for maximum cable length. Stranded 22 AWG wire should not be used for cable runs greater than 61 meters. If 22 AWG is used with EPIC type connector options the wire ends should be tinned.

FAULT-CHECK

After power-up and the rotor position is checked by the sensor, the Fault-Check LED will turn GREEN.

If the adaptive electronics reach their adjustment limit for any reason, the Fault-Check alarm and LED will notify the drive and operator of an impending failure. The LED will turn RED if the Adaptive Electronics reach their adjustment limit. This output occurs before an actual failure, allowing steps to be taken to replace the unit before it causes unscheduled downtime. Fault-Check annunciation is available as an "alarm" output through the connector and as an integral LED.

TROUBLESHOOTING

If the drive indicates a loss of encoder/tach fault and the AV56A fault-check LED is not illuminated, check the encoder power supply. If power is present, check polarity; one indicator of reversed power supply is that all outputs will be high at the same time. If the drive indicates encoder fault, but the LED shows GREEN, then check the wiring between the drive and the encoder. If the wiring appears correct and in good shape, test the wiring by replacing the AV56A. If the new unit shows GREEN, and the drive still shows encoder loss/tach fault, then the wiring is faulty and should be repaired or replaced.

If the alarm output and/or LED indicate a fault (RED):

1. Remove the rear cover, and use the built-in gauge to check the location of the rotor (see Figure 1). Ensure the label marked "This side out" and/or cam screws is/are facing away from the motor.
2. Remove the AV56A from the motor. Clean the housing mounting surface for the AV56A housing. Ensure the AV56A is directly mounted on the motor, with no sealant, gasketing, or other materials, and is firmly bolted in place.

If the alarm output and/or LED indicate a fault (RED)

On a properly mounted AV56A and the rotor is properly located, replace the AV56A.

An oscilloscope can also be used to verify proper output of the encoder at the encoder connector itself and at the drive/controller cabinet. If the outputs show large variations in the signals at steady speed (jitter or "accordion effect", see figure 5), check rotor position. If the rotor position is correct, the motor or shaft may be highly magnetized. Replace any magnetized material nearby with non-magnetic material (aluminum, stainless) (especially shafts). For GE CD frame motors and similar styles, Avtron offers non-magnetic stub shafts. If variations persist, consider replacing the encoder with super-shielded models, option -005, or use retrofit shielding kits AVSKxxx yy z, where xxx=model (ex: 56A), yy=rotor (ex: CB), and z=cover (ex: F).

If the alarm output and/or LED indicate a wiring fault (ORANGE):

Remove all output wires/connections (A,A',B,B',Z,Z'). The LED should turn GREEN. If the LED does not turn GREEN, the encoder is not receiving enough voltage at +V to properly operate. Correct input voltage problem at power supply or cabling.

If the LED turns GREEN once all outputs are disconnected, reconnect each output, one at a time, monitoring for ORANGE LED. For partial/resistive short circuits, the LED may take a few minutes to turn ORANGE. To speed the troubleshooting process, if possible, spin the encoder while replacing individual output connections. This will make the ORANGE LED condition occur faster. Once the shorted output(s) are located, correct the shorting condition, and the encoder LED should remain GREEN.

If the LED is OFF, but power is being applied to the encoder, check the output voltage level at A, A', B, B'. If all outputs are ON ($\approx +V$), the connections to +V and COM are reversed. Swap connections between +V and COM; the LED should turn GREEN.

NOTE:

Do not use rotors from THIN-LINE I (M56, M56S, M67, M85, M115) with THIN-LINE III. This will cause incorrect PPR output, but the Encoder LED will remain green.

ENCODER REMOVAL

The AV56A stator housing can be removed by loosening and removing the socket head cap screws.

CAM SCREW ROTOR REMOVAL

Disengage the (2) cam screws by turning them counterclockwise less than 1 full turn. The cam heads will visibly move away from the shaft. Remove the rotor by hand by pulling it away from the motor. If the rotor will not move, do NOT use a gear puller, and do not use a heat gun. Instead, insert two M6 screws, >25mm length into the Jack Screw Holes shown in Fig 2. Alternately tighten the screws to push the rotor away from the motor and remove it.

LARGE BORE SET SCREW ROTOR REMOVAL

Disengage the (2) set screws by turning them counterclockwise until removed from the rotor. Retain the set screws. Remove the rotor by hand by pulling it away from the motor. If the rotor will not move, do NOT use a gear puller, and do not use a heat gun. Instead, pry the rotor away from the motor gently, being careful to only pry against the rotor metal hub and not the magnetic outer strip.

CONNECTOR SPARE PARTS							
STYLE	OPTION CODE	ENCODER SIDE		CABLE SIDE PLUG			
Industrial EPIC on Encoder	P,G	315233	Base	315937	Hood	Conn1-02	
		315229	Terminal	315936	Terminal		
Industrial EPIC w/ Adapter Block	Q			401112	Adapter	Conn1-02	
Industrial EPIC on 3' Cable	Z	315232	Surface	315937	Hood	Conn1-02	
		315229	Terminal	315936	Terminal		
		471819	Bushing	401112	Adapter		
Mini-MS Twist Lock	R, S	315296	Base	316110	Plug		
10 pin MS	Y	314383	In-Line	315932	Plug	Conn1-01	
				411216	Cable Bushings		
				411217			
				411218			
10 pin MS	A, B, C, D			411219		Cable Bushings	Conn1-01
		315933	Base	315932	Plug		
				411216	Cable Bushings		
				411217			
		411218					
				411219			

FIGURE 1

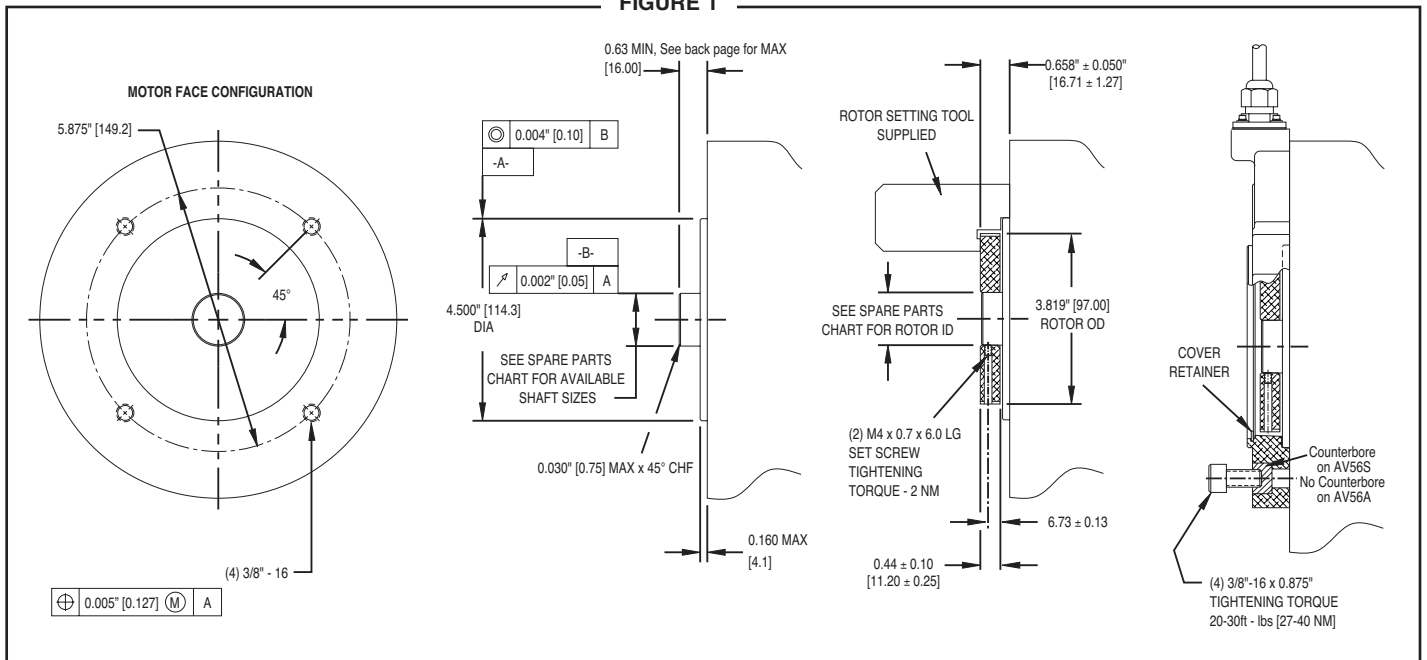

FIGURE 2

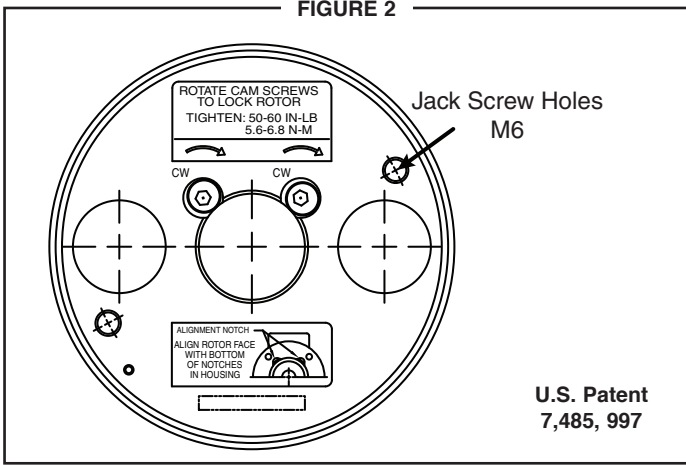

FIGURE 3

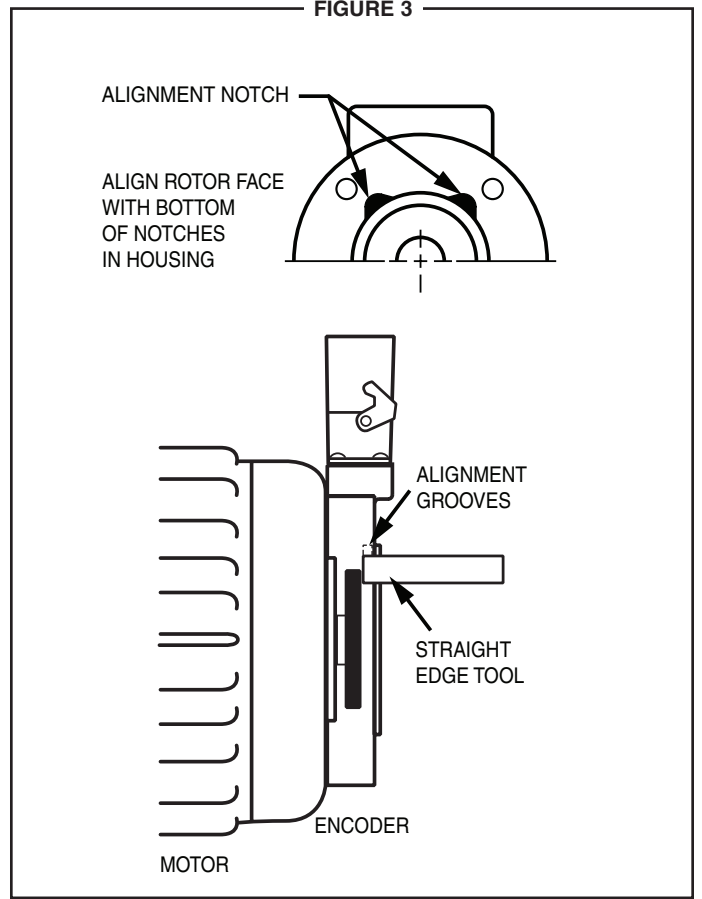

FIGURE 4

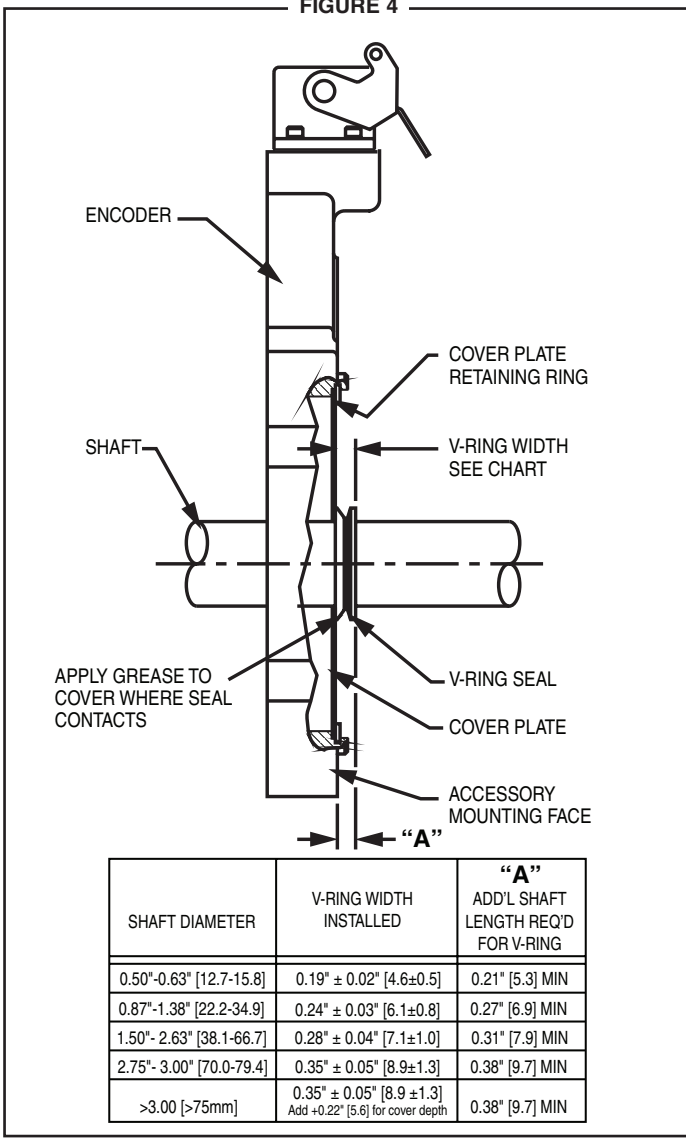
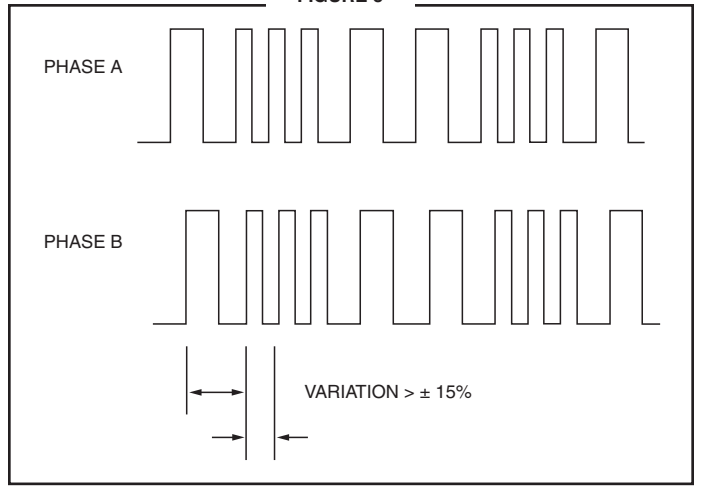

FIGURE 5



**THIN-LINE II & III Spare Parts
(AV56A/AV67/AV85/AV115 Only) SAE/USA Sizes**

Shaft Size	Thru-Shaft Covers				
	Cam Screw Rotor	Set Screw	AV56, AV67 & AV115 Cover Kit	AV85 Cover /kit	Seal Only
.500/.4995	AVTR1-CA	N/A	A36521-TA	A36523-TA	471960
.625/.6245	AVTR1-CB	N/A	A36521-TB	A36523-TB	471877
.875/.8745	AVTR1-CC	N/A	A36521-TC	A36523-TC	471963
.9375/.9370	AVTR1-CD	N/A	A36521-TD	A36523-TD	471963
1.000/.9995	AVTR1-CE	N/A	A36521-TE	A36523-TE	471964
1.125/1.1245	AVTR1-CF	N/A	A36521-TF	A36523-TF	471965
1.250/1.2495	AVTR1-CG	N/A	A36521-TG	A36523-TG	471967
1.375/1.3745	AVTR1-CH	N/A	A36521-TH	A36523-TH	471952
1.500/1.4995	AVTR1-CT	N/A	A36521-TT	A36523-TT	471969
1.625/1.6245	AVTR1-CJ	N/A	A36521-TJ	A36523-TJ	471969
1.750/1.7495	AVTR1-CK	N/A	A36521-TK	A36523-TK	471970
1.875/1.8745	AVTR1-CL	N/A	A36521-TL	A36523-TL	471970
2.000/1.9995	AVTR1-CM	N/A	A36521-TM	A36523-TM	471971
2.125/2.1245	AVTR1-CN	N/A	A36521-TN	A36523-TN	471972
2.250/2.2495	AVTR1-CQ	N/A	A36521-TQ	A36523-TQ	471972
2.375/2.3745	AVTR1-CP	N/A	A36521-TP	A36523-TP	471953
2.500/2.4995	AVTR1-CR	N/A	A36521-TR	A36523-TR	471954
2.625/2.6245	N/A	AVTR1-TS	A36521-TS	A36523-TS	471954
2.750/2.7495	N/A	AVTR1-TW	A36737-TW	A36523-TW	471955
2.875/2.8745	N/A	AVTR1-TU	A36521-TU	A36523-TU	471956
3.000/2.9995	N/A	AVTR1-TV	A36521-TV	A36523-TV	471956
3.1250/3.1245	N/A	AVTR2-T4	A36737-T4	A36523-T4	471957
3.1875/3.1870	N/A	AVTR2-T7	A36737-T7	A36523-T7	471957
3.250/3.2495	N/A	AVTR2-TZ	A36737-TZ	A36523-TZ	471957

Extended and Flat Cover Plates				
Shaft Size	Model	Extended Shaft Cover	Flat Cover	Dome Cover
Any	AV56A, AV67, AV115	A35841	A37298	B29992-3
Any	AV56S	A36526	A37298	N/A
Any	AV85	A35841	A36525	N/A

**THIN-LINE II & III Spare Parts
(AV56A/AV56S/AV67/AV85/AV115 Only) Metric Sizes**

Shaft Size	Rotors AV56A, AV67, AV85, AV115			Thru-Shaft Covers		
	Option Code	CAM Screw	Set Screw	AV56, AV56S, AV67 & AV115 Cover Kit	AV85 Cover /kit	Seal Only
10mm	D2	AVTR1-D2	N/A	A36522-M2	A36524-M2	471959
11mm	DA	AVTR1-DA	N/A	A36522-MA	A36524-MA	471959
12mm	D3	AVTR1-D3	N/A	A36522-M3	A36524-M3	471960
14mm	DB	AVTR1-DB	N/A	A36522-MB	A36524-MB	471961
15mm	DC	AVTR1-DC	N/A	A36522-MC	A36524-MC	471961
16mm	DD	AVTR1-DD	N/A	A36522-MD	A36524-MD	471877
18mm	D4	AVTR1-D4	N/A	A36522-M4	A36524-M4	471962
19mm	DE	AVTR1-DE	N/A	A36522-ME	A36524-ME	471951
24mm	DF	AVTR1-DF	N/A	A36522-MF	A36524-MF	471964
28mm	DG	AVTR1-DG	N/A	A36522-MG	A36524-MG	471965
30mm	DH	AVTR1-DH	N/A	A36522-MH	A36524-MH	471966
32mm	DT	AVTR1-DT	N/A	A36522-MT	A36524-MT	471967
36mm	DJ	AVTR1-DJ	N/A	A36522-MJ	A36524-MJ	471968
38mm	DK	AVTR1-DK	N/A	A36522-MK	A36524-MK	471969
42mm	DL	AVTR1-DL	N/A	A36522-ML	A36524-ML	471969
45mm	DM	AVTR1-DM	N/A	A36522-MM	A36524-MM	471970
48mm	DN	AVTR1-DN	N/A	A36522-MN	A36524-MN	471971
52mm	DP	AVTR1-DP	N/A	A36522-MP	A36524-MP	471971
55mm	DR	AVTR1-DR	N/A	A36522-MR	A36524-MR	471972
60mm	DS	AVTR1-DS	N/A	A36522-MS	A36524-MS	471953
65mm	MU	N/A	AVTR1-MU	A36522-MU	A36524-MU	471954
70mm	MV	N/A	AVTR1-MV	A36522-MV	A36524-MV	471955
75mm	MW	N/A	AVTR1-MW	A36522-MW	A36524-MW	471956
80mm	MY	N/A	AVTR1-MY	A36737-MY	A36524-MY	471957
85mm	MZ	N/A	AVTR2-MZ	A36737-MZ	A36524-MZ	471958

WIRING DIAGRAMS

FOR DIFFERENTIAL APPLICATIONS

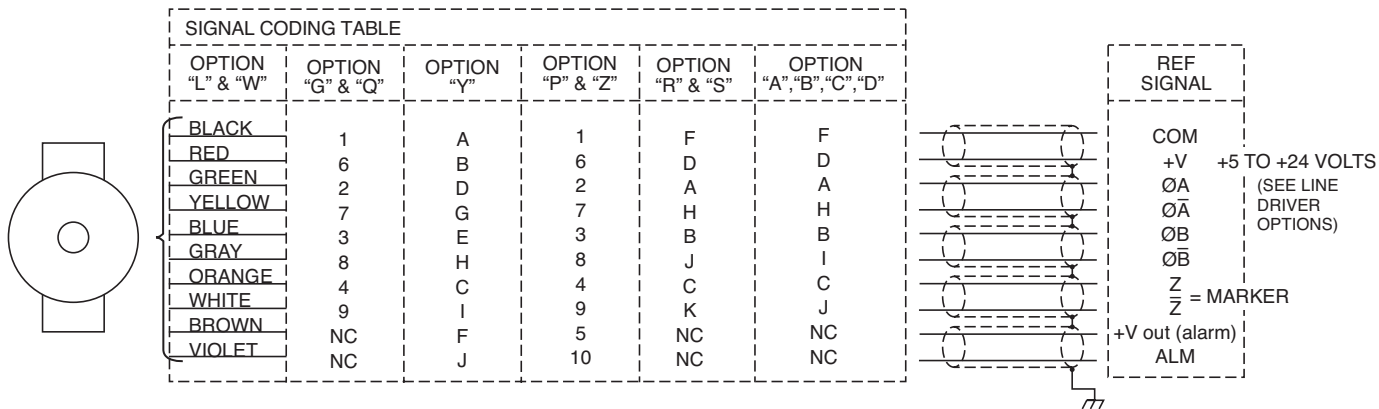

FOR SINGLE ENDED TWO PHASE APPLICATIONS

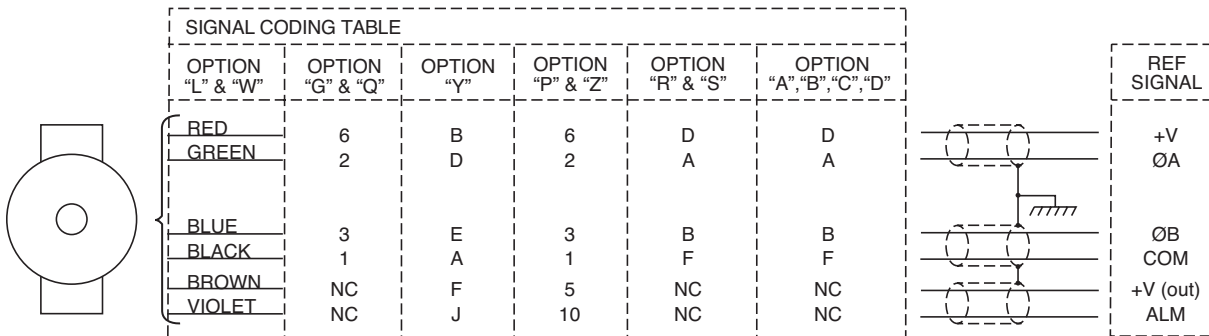

FOR SINGLE ENDED SINGLE PHASE APPLICATIONS

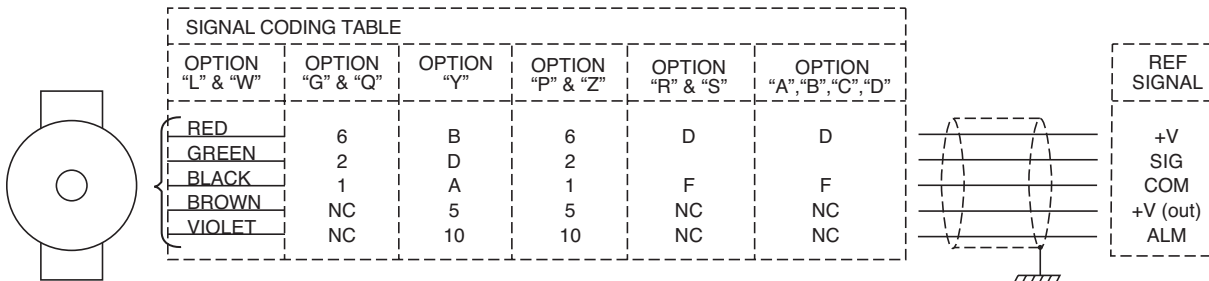

FOR DIFFERENTIAL APPLICATIONS

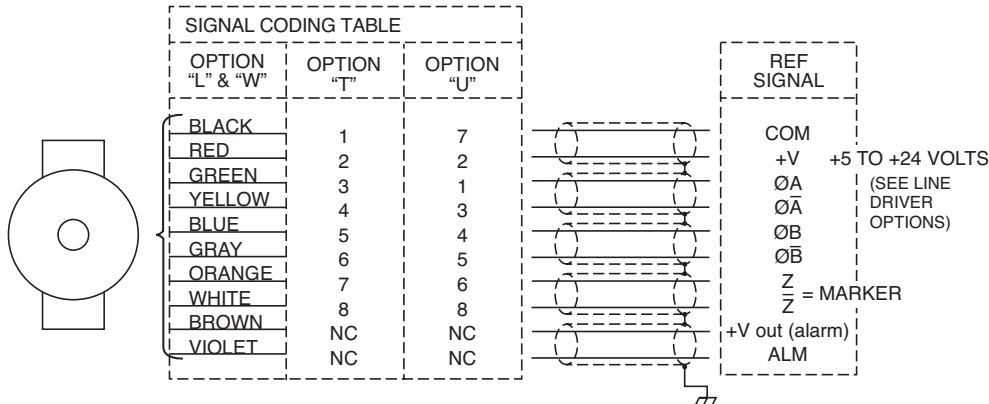

TYPICAL WIRE SELECTION CHART
for 18 AWG, multiple pair, individually shielded

	BELDEN	ALPHA
2 PAIR	9368	5620B1802
3 PAIR	9773 or 9369	6445
4 PAIR	9388	6444
3 CONDUCTOR	9365	5640B1801

For option "W", unused outputs must be insulated to prevent accidental contact.

*NOTE: Single ended wiring not recommended for line driver option "8"

THIN-LINE II™ & III™

Application Examples

Applies to AV56A models, except wiring options "A", "B", "C", "D", "G", "Q", "R", "S", "T" and "U".

ALARM OUTPUT CONNECTION

Avtron THIN-LINE II & III encoders provide an alarm signal if maintenance is required under specific circumstances. An alarm LED indicator is also available. Green indicates power on, red or orange indicates alarm on. Following are application examples provided to help install the alarm output.

Example 1. Alarm output using +V(OUT). +V(OUT) is equal to +V, the encoder power supply.

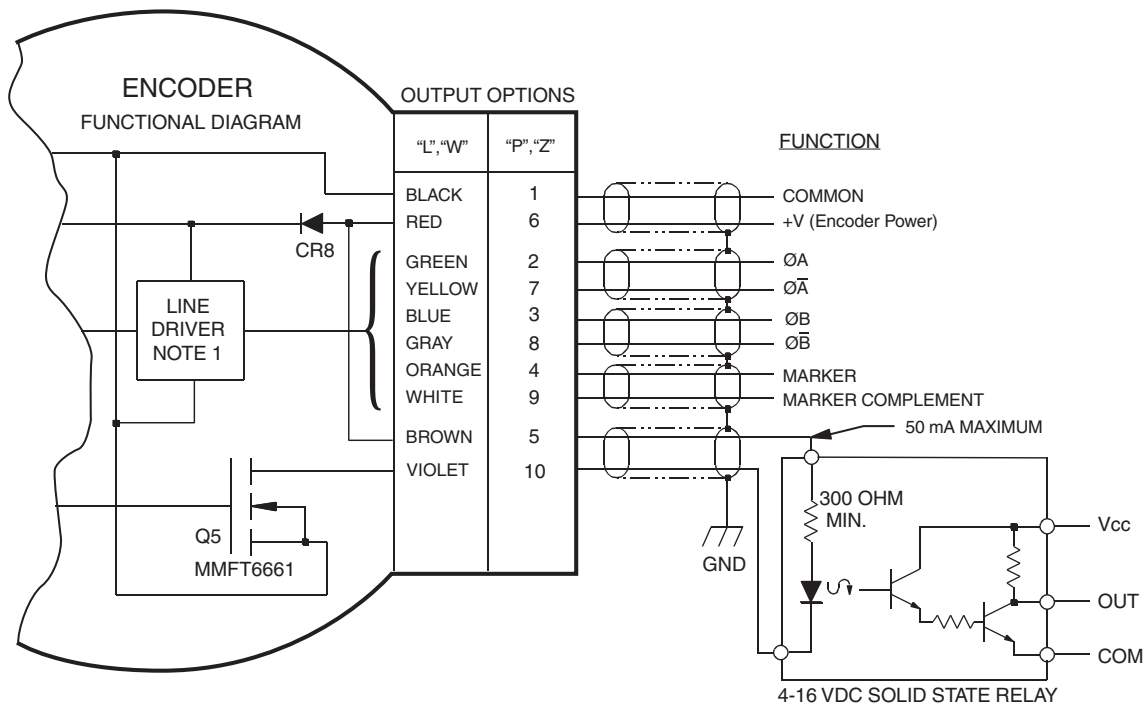

Example 2. Alarm Output Using Separate 24 VDC Power Supply and Relay.

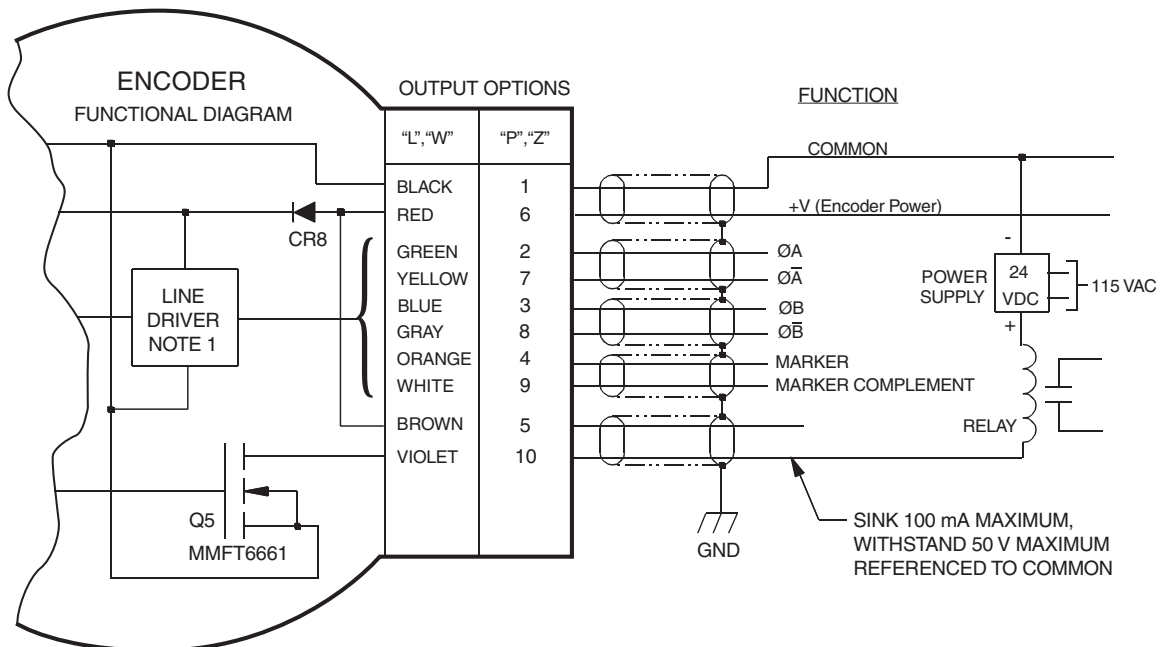

OUTLINE DRAWING

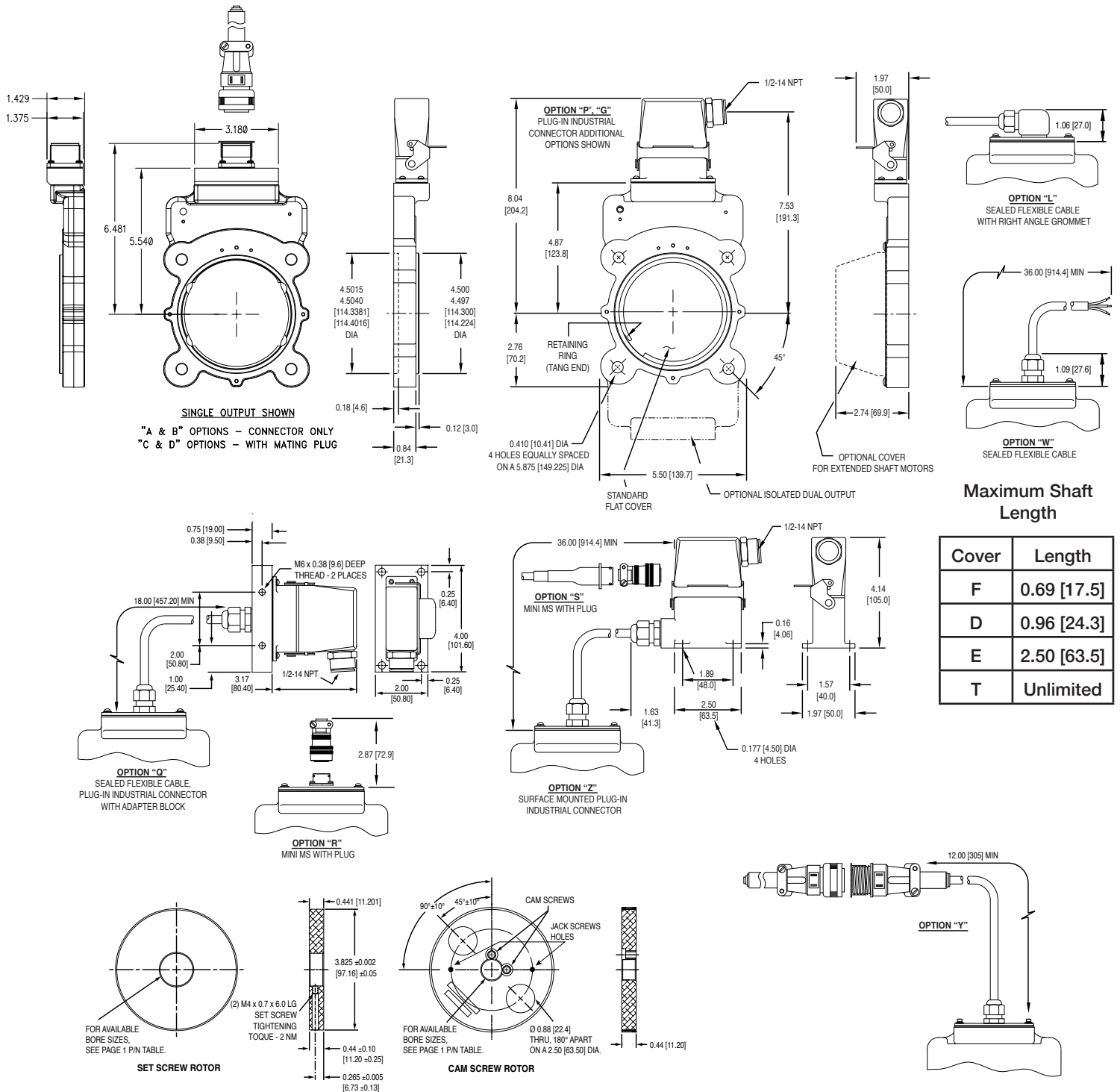

3 - DIMENSIONS IN INCHES [MILLIMETERS]
 2 - ALL DIMENSIONS ARE APPROXIMATE
 1 - WEIGHT: 2.5 - 4LBS [1.13 TO 1.81 KG].
 NOTES:



CE Pending

Features and specifications subject to change without notice.
 Avtron standard warranty applies. All dimensions are in millimeters approx.

Nidec-Avtron Makes the Most Reliable Encoders in the World

8901 E. PLEASANT VALLEY ROAD • INDEPENDENCE, OHIO 44131-5508
 TELEPHONE: (1) 216-642-1230 • FAX: (1) 216-642-6037
 E-MAIL: tachs@nidec-avtron.com • WEB: www.avtronencoders.com