

AVTRON INCREMENTAL ENCODER

Model: AV850 SMARTach™ III 8-1/2" FC FACE MOUNT MODULAR

GENERAL

The Avtron Model AV850 SMARTach™ III is an incremental encoder (also known as tachometer or rotary pulse generator), allowing operation down to zero RPM. It provides a specific number of electrical Pulses Per Revolution (PPR) that are proportional to a shaft's revolution. The AV850 SMARTach III is a bearingless, couplingless, modular design, providing unequaled reliability and mechanical performance.

The AV850 fits AC and DC motors with an 8.5" C (FC / 180) Face. Both end-of-shaft and through shaft mountings are accommodated. The AV850 Encoder consists of three or four parts: a rotor, a stator housing, and one or two removable sensor modules. No gapping, adjustment, or shimming is required!

An Avtron AV850 SMARTach III is equipped with one or two AV5 sensor modules. Each module has a two-phase output (A, B) 90° out of phase, with complements (A, B), (A Quad B Output), and a marker pulse with complement (Z, Z̄). For applications which require more than 2 independent outputs, AV850 encoders may be stacked via the use of shaft adapters (see Table 2 for part numbers). Two separate encoders would be purchased.

Output resolution on the AV850 is determined by the sensor only. Unlike older models, any PPR's can be mixed and matched. Selection of the rotor is based only on the shaft mounting requirements (and not PPR).

The AV5 removable sensor assembly has a diagnostic package that includes Adaptive Electronics and a Fault-Check output. With this package, the SMARTach III can maintain itself, and let you know if there is a problem before the problem causes unscheduled downtime.

SECTION II: INSTALLATION

GENERAL

The motor must comply with NEMA MG1 for dimensions, face runout, and shaft runout. Axial float or endplay must be less than +/-0.100" inch.

INSTALLATION HARDWARE

Installation hardware required is attached to each assembly. Equipment needed for installation

Equipment Needed for Installation		
Provided	Optional	Not Provided
AV850 Encoder - Washer, Spring Lock 1/2 (4) - Hex Hd. Cap Screw 1/2-13 x 3.00 (4)	- A35226 Gauge or A25355 M285/AV850 Rotor Gauge Block - Inboard Through-Shaft Seal Plate	- 3/4" Wrench - Phillips Screwdriver - 7/16" Nut Driver - Dial Indicator - Vernier Caliper
Rotor - Rotor Installation Hardware Kit - Anti-Seize Compound (copper) - Thread Locker (blue)	- Outboard Through-Shaft Seal Plate Kit - Silicone Lubricant or 20 Weight Machine Oil - Dead Blow Hammer - Large Frame Adapter Kit (Modification "700") AV850 Shield Kit (A35355)	- 3/32" Hex Wrench (T-Handle style) (thru shaft rotors only) - 3/16" Hex Wrench (cam screw rotors only) - 9/16" Wrench (end-of-shaft rotors only)

(OPTIONAL) LARGE MOTOR STATOR ADAPTER INSTALLATION (Modification "700", "704")

For large frame GE CD motors Avtron offers a frame adapter to add an 8.5" C-face to the motor. To install the flange adapter:

1. Remove all existing adapters on the non-drive end of the motor.
2. Clean the motor flange.
3. Using the supplied hardware, bolt the flange adapter in place (see Figure 1).
4. Apply anti-seize to the frame adapter C-face flange.

(OPTIONAL) INBOARD SEAL PLATE INSTALLATION (Cover Plate "B" & "N")

For installations where the AV850 will be mounted to an open frame flange adapter, or other installation where the inner surface of the AV850 will not form a seal with the rear end bell of the motor, Avtron offers inboard, through-shaft seal plate kits. These kits include a cover plate and seal. See Table 3 for part numbers. To install the inboard through-shaft seal plate kit:

1. Verify all components fit the motor shaft (rotor, V-ring seal, and seal plate).
2. Slide V-ring seal onto motor shaft.
3. Apply a light coating of silicone lubricant or medium grade machine oil to the outward face of the seal.
4. Use the seal plate to push the seal on the shaft; stop when the seal plate contacts the motor face. Remove the seal plate and push the V-ring seal an additional 0.09" [2.29mm] toward motor.
Verify the V-ring seal is clear of the motor bearings and housing. V-ring seal compression should be between 0.03" and 0.09" [0.75mm-2.29mm] in final position when plate is reapplied.
5. Remove the double-stick tape protection. Align the bolt holes.
6. Stick the inner cover plate in place.
7. Mount rotor per instructions below, but increase axial position from motor to rotor to 0.620" [15.75mm] (from 0.584") to accommodate the inner seal plate thickness. See Figure 3.
8. Mount remainder of AV850 per instructions on next page.

MAGNETIC SHIELD INSTALLATION

For top performance on older motors with magnetized shafts and frames install the AV850 shield. The AV850 also has built-in shields attached to the housing of every unit. The standard AV850 shield as provided will fit shafts up to 3" [76mm]. For larger shafts, if desired, the shield can be custom-cut by the customer to fit a larger bore (recommend +0.125" [3.1mm] over shaft size), or the shield can be omitted, as its effectiveness is reduced beyond a 3" bore size.

NOTE

For additional magnetic field protection, consider the -004 option for extra sensor shielding.

1. Remove the double-stick tape protection.
2. Align the bolt holes and edges with the motor C-face.
3. Stick the shield in place on the motor C-face or on top of any inboard seal plate.
4. Install rotor as usual, but gage location from the shield. See Figure 3.

The outer edge of the rotor may be damaged by scratches, severe blows, and strong magnetic fields.

TABLE 1

AV850 PART NUMBERS AND AVAILABLE OPTIONS														
Model	Rotor Style	Shaft Size	Inboard & Outboard Cover Plates	Left Module				Right Module				Connector Options	Modifications	
				Line Driver	PPR			Line Driver	PPR					
AV850			X- none D- no inboard, domed outboard cover plate B- inboard, thru outboard ⁺ F- no inboard, flat outboard N- inboard, flat outboard ⁺ T- no inboard, thru outboard ⁺	X- none 6- 5-24V in/out (7272) 8- 5-24V in/out (HX) 9- 5-24V in, 5V out (7272)	X- none F- 60 C- 64 G- 100 H- 120 A- 128 L- 240 N- 256 P- 300 E- 360	B- 480 Q- 500 R- 512 S- 600 U- 720 V- 900 J- 960 W- 1000 Y- 1024 Z- 1200	2- 1500 6- 1800 3- 2000 4- 2048 5- 2500 D- 4096 8- 4800 9- 5000 0- special	X- none 6- 5-24V in/out (7272) 8- 5-24V in/out (HX) 9- 5-24V in, 5V out (7272)	X- none F- 60 C- 64 G- 100 H- 120 A- 128 L- 240 N- 256 P- 300 E- 360	B- 480 Q- 500 R- 512 S- 600 U- 720 V- 900 J- 960 W- 1000 Y- 1024 Z- 1200	2- 1500 6- 1800 3- 2000 4- 2048 5- 2500 D- 4096 8- 4800 9- 5000 0- special	000- none 003- Include analog signal converter (K661) 004- Super sensor shielding 4xx- Special PPR (see chart) 700- Large Motor Stator Adapter ⁺		
Connector Options														
Mounted on Encoder Body														
				5 pin MS			10 pin MS			Other	3' Cable			5' Flexible Conduit
Industrial Connector									Industrial Connector		TwistLock	Other		
P- Large, with Plug		E- (M737 Pinout) without Plug		A- without Plug		K- Condulet with Leads		Z- Large, with Plug		S- Mini MS without Plug		W- Leads only	N- Leads only	
G- Large, (Northstar™ Pinout) with Plug		F- "E" with Plug		B- with Plug		R- Mini MS TwistLock with Plug		Q- Large, with Plug on Remote Base, 18" cable					T- Terminal box	
1- Small, (M3/M4 Pinout)		H- (M727 Pinout) without Plug		C- with Plug & Flex. Conduit Adapter		3- 6 Pin MS connector (M940 Pinout)								
		J- "H" with Plug		L- with Right Angle Plug										

Spare sensors, rotors, through-shaft cover plates, and shaft grounding kits can be ordered separately. (See Tables 2, 3, and 4)

Cam screw rotors patented.

TABLE 2

+ Large motor stator adapter required if not previously installed. > N/A for End of Shaft rotor styles. • Rotor Style "T" only.

Rotor Style	Shaft Size									
T- Thru Shaft (Inch)	A- 0.750	E- 1.000	J- 1.625	M- 2.000	Q- 2.250	W- 3.250	2- 2.875	G- 3.750•	6- 4.500•	
C- Thru Shaft, Cam Screw (Inch)	B- 0.625	F- 1.125	K- 1.750	N- 2.125	R- 2.500	Y- 3.375	3- 3.500	4- 3.875•		
	C- 0.875	H- 1.375	L- 1.875	P- 2.375	T- 2.625	Z- 3.421	D- 3.625•	1- 4.000•		
M- Thru Shaft (mm)	F- 30mm	P- 60mm	Z- 80mm (2)	1) For Shaft DIA 80		2) For Shaft DIA 80				
	J- 42mm	Y- 80mm (1)	4- 95mm	-.030/-0.047mm (f6)		+.0/-0.030mm (h7)				
E- End of Shaft	F- 1.125 GE CD180-320		P- 2.375 GE CD400		2- 2.875 GE CD500		9- GE CD6000, 6100, 6200, 6700, 6800, & 6900			
H- End of Shaft for Grounding Kit	N- 2.125 GE CD360		Q- 2.250 GE CD444/505E							
U- Universal with End of Shaft	F- 1.125 GE CD180-320		9- GE CD6000, 6100, 6200, 6700, 6800, & 6900		Y- GE CD4600, 4700, 8500, & 8600*		U- Universal (Includes 1 Rotor and Shaft adapters for all motors except Q, R, Z & 4)			
G- Universal with Grounding Kit	N- 2.125 GE CD360		V- GE CD4300, 4400, 5400, 6400 & 6500*		Z- GE CD680*		Q- GE CD444/505E*			
P- EOS Adapter for Stacked Encoders	P- 2.375 GE CD400		W- GE CD4500, 7500, 7600*		4- ABB 95mm					
	2- 2.875 GE CD500									
	R- GE CD507, 509									
K-Keyway Thru Shaft, Cam Screw (Inch)	E- 1.000									
X- no rotor	X- no rotor									

AV5 Sensor										
Model	Line Driver	PPR						Connector Options	Modifications	
AV5-	6- 5-24V in/out (7272) 8- 5-24V in/out (HX) 9- 5-24V in, 5V out (7272)	X- none F- 60 C- 64 G- 100 H- 120 A- 128	L- 240 N- 256 P- 300 E- 360 B- 480 Q- 500	R- 512 S- 600 U- 720 V- 900 J- 960 W- 1000	Y- 1024 Z- 1200 2- 1500 6- 1800 3- 2000 4- 2048	5- 2500 D- 4096 8- 4800 9- 5000 0- special	See above list	000- none 004- Super magnetic shielding 4xx- Special PPR (see chart)		

SPECIAL PPR OPTION CODES								
4xx Code	PPR (Left)	PPR (Right)	4xx Code	PPR (Left)	PPR (Right)	4xx Code	PPR (Left)	PPR (Right)
401*	1270	None	408	1400	None	415	3000	None
402*	150	None	409*	30	None	416	3600	None
403*	50	None	410	None	6000	417	1250	None
404	None	16	411	12000	None	418	2400	2400
405	16	None	412	200	None	419	160	160
406	6000	None	413*	30	30	420	450	None
407	2800	None	414	1500	None			

NOTE
 Special option 4xx selects an alternate PPR code definition. Example: PPR Code 0, special option code 401=1270 PPR (Left) / no right output.

ROTOR INSTALLATION

Use the dial indicator gauge to ensure motor shaft runout (TIR) does not exceed (0.004") [0.10mm]. Apply anti-seize compound to the shaft.

CAUTION

Do not strike the encoder or rotor at any time. Damage will result and the warranty will be void. At installation, clean and remove paint and burrs from motor shaft and mounting face. Apply anti-seize compound (supplied) to each EXCEPT CAM SCREW ROTORS.

UNIVERSAL END-OF-SHAFT APPLICATIONS: (Rotors GF-G9, UF-U9, QF-Q9)

See Table 2 for part numbers.

1. Verify the shaft projection from the C-face of the motor is 0.400".
2. GE CD180-320 style kits (-UF) require a roll pin (included) to be inserted into the shaft hole before installation of the stub shaft adapter.
- 2a. Install the shaft adapter on the motor using the bolts, threadlocker and washers provided.
3. Verify the stub shaft runout/wobble is less than 0.004" TIR. (0.001" is ideal). Use a dead blow hammer or shims (provided) to true the shaft as needed.
4. Slide the rotor onto the stub shaft. The space between the mounting face and the magnetic strip of the rotor must be set to 0.584", as shown in Figure 2. Use Avtron gauges (A25355 or A35226) or use housing alignment grooves as shown in Figure 5 to verify position.

NOTE

If optional inboard seal plate and/or magnetic shield is used, gage the rotor location from the shield/seal plate(s). Ensure the rotor label marked "this side out" is facing away from the motor.

- 4a. For rotors UN, UP, and UQ ensure the counter bored holes on the motor side of the rotor line up with the bolt heads used to mount the adapter. This will permit proper rotor axial positioning.

5. Turn the cam screws of the rotor in the directions shown on the rotor to engage the cams. Tighten to 9-10 ft-lb (12.2-13.5 n-m). **Total cam screw rotation will be less than one turn.**

END-OF-SHAFT APPLICATIONS (Rotors EF-E9, HF-H9)

See Table 2 for part numbers:

1. Verify that the shaft projection from the C-face of the motor is 0.400" [10.2mm]. Apply anti-seize to the shaft.
 - 1a. GE CD180-320 style kits (-EF) require a roll pin (included). Install the pin in the rotor first, then position the rotor on the shaft. Lightly tap into place.
 2. Apply threadlocker to the bolt(s); use the supplied washer(s) and tighten.

THROUGH SHAFT APPLICATIONS (Rotors TA-T9, CA-C9, MF-MZ, KA-K9)

See Table 3 for part numbers:

1. The through-shaft must project at least 1.5" [38.1mm] from the accessory mounting face. If it is greater than 2" [50.80mm] long, use the outboard through-shaft cover, detailed in Figure 4.
2. Slide the rotor on the shaft (option "B" or "T"), ensuring the rotor label "this side out" is away from the motor. The space between the mounting face and the rotor must be set to 0.584" [14.83mm], as shown in Figure 2. Use Avtron gauges (A35226 or A25355) or housing alignment grooves as shown in Figure 5 to verify position. (Note: if optional inboard seal or shield plate is used, gage the rotor location from the seal shield plates. See Figure 3.)
 - 2a. If using a set screw rotor (TA-T6), apply threadlocker to the set screws (2) and tighten to 25 in-lbs.
 - 2b. If using a cam screw rotor (CA-C3), threadlocker is pre-applied. Turn the cam screw(s) of the rotor in the directions shown on the rotor to engage the cams. Tighten to 9-10 ft-lb (12.3- 13.5 n-m). **Total cam screw rotation will be less than one turn.**

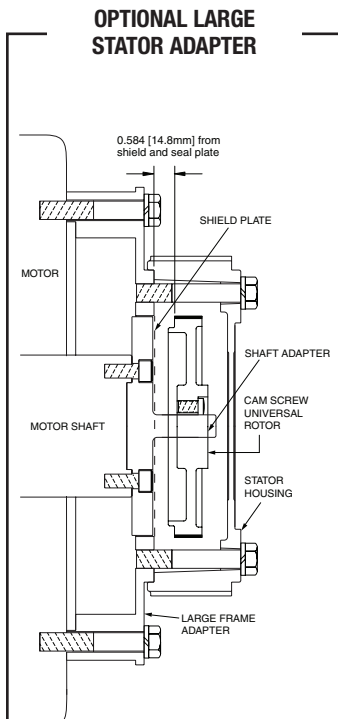

FIGURE 1

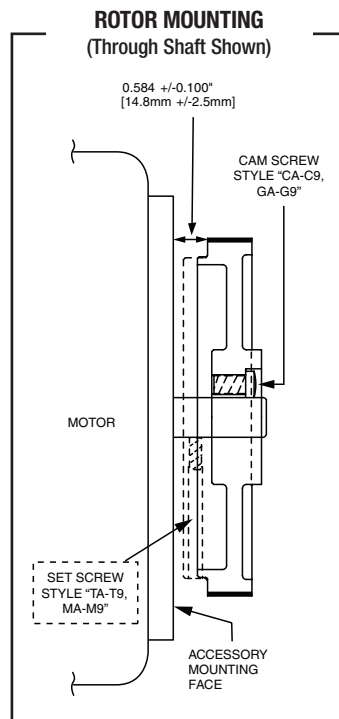

FIGURE 2

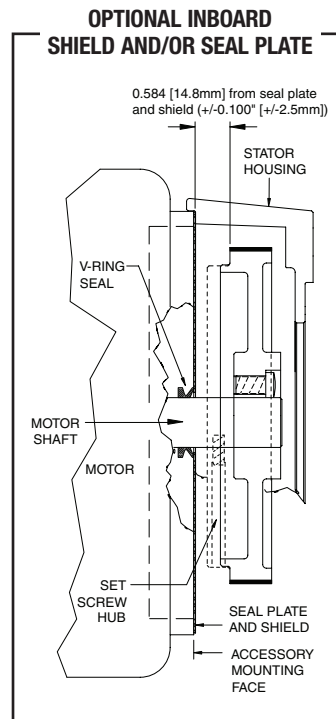

FIGURE 3

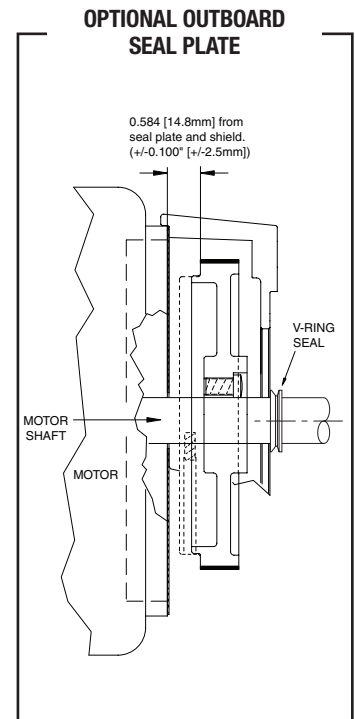

FIGURE 4

STATOR HOUSING INSTALLATION

NOTE

If additional magnetic shielding (option 004) has been added to the sensors, be sure to remove the sensors before installing the stator housing.

The stator housing is retained to the motor using four, 1/2-13 x 3" bolts and spring type lock washers (supplied). If the stator is to be sandwich mounted between an accessory such as a brake and the motor, select the bolt length accordingly. Apply anti-seize compound to the perimeter of the AV850 where it will contact the motor C-face.

Carefully move the stator housing into position, avoiding contact with the rotor. DO NOT FORCE the housing into place. Install the four mounting bolts (torque 30 to 35 foot pounds) [47.5-40.6 n-m].

CAUTION

DO NOT use silicone sealants or caulk of any kind on the motor or encoder face; these can cause misalignment or sensor scraping damage. Do apply anti-seize compound (copper) to the encoder face to assist in easy removal. The AV850 electronics are fully sealed; water may enter and leave the rotor area as needed. Remove the bottom pipe plug in the housing if frequent moisture buildup is expected.

(OPTIONAL) OUTBOARD SEAL PLATE KIT INSTALLATION.

For applications requiring shafts to pass completely through the AV850, Avtron offers an outboard through-shaft seal plate kit with V-ring seal. See Table 4 for part numbers and Figure 4.

1. Install the encoder rotor as shown above.
2. Remove the existing cover of the encoder. Retain the screws and washers.
3. Mount the AV850 stator housing as shown in Figure 4.
4. Install new through-shaft cover using the (4) #10-24 screws and washers from step 2.
5. Apply silicone lubricant or medium grade machine oil (20 weight) to the outboard side of the cover where the V-ring seal will contact it.
6. Slide the V-ring seal onto the shaft, and ensure that it is compressed against the cover. See installation Figure 4.

(OPTIONAL) SHAFT GROUNDING KIT INSTALLATION (Rotors "FA-F9", "GA-G9")

Refer to separate Shaft Grounding Kit Instructions (M190-AV850)

(OPTIONAL) CHECK ROTOR POSITION

1. Remove a sensor or blank side cover plate.
2. Verify the rotor magnetic stripe is aligned with the grooves (see Figure 5).
3. Replace the sensor or side cover plate.

WIRING INSTRUCTIONS

CAUTION

Remove power before wiring.

Wiring diagrams are shown in Figure 6 and 7.

For bidirectional operation of the encoder, proper phasing of the two output channels is important. Phase A channel leads phase B channel for clockwise shaft rotation as viewed from the anti-drive or accessory end of the motor (encoder mounting end). Wiring option "G" provides a pinout compatible with Northstar™ encoders, with a cable shield connection on pin 10. Note that this option does not ground the shield; Avtron still recommends grounding the shield at the drive end of the cable for all wiring options.

CORRECTIVE ACTION FOR PHASE REVERSAL

- 1) Remove Power.
- 2) Exchange wires on cable, either at encoder cable end or at speed controller end (but not both).
 - a. Single Ended 2 Phase Wiring (see wiring diagram) Exchange A and B at the use end of the wires.
 - b. Differential 2 Phase Wiring (see wiring diagram) Exchange either A with A in the phase A pair OR B with B in the phase B pair but NOT both.
- 3) Apply power.
- 4) Verify encoder feedback is correct, using hand rotation of shaft, or jog mode of the speed controller.

Interconnecting cables specified in the WIRE SELECTION CHART in Figure 6 are based on typical applications. Refer to the system drawing for specific cable requirements where applicable.

Physical properties of cable such as abrasion, temperature, tensile strength, solvents, etc., are dictated by the specific application.

General electrical requirements are: stranded copper, 22 thru 16 gauge (Industrial EPIC Connector options can use 14-20 AWG), each wire pair individually shielded with braid or foil with drain wire, 0.05 uF maximum total mutual or direct capacitance, outer sheath insulator, 1,000 ft. max. See WIRE SELECTION CHART in Figure 6 for some suggested cables.

See Figure 7 for examples of alarm output wiring.

NOTE

When using the industrial connector ("1", "G", "P", "Q", "V", "X", or "Z" options), the minimum wire size is 20 gage, and 20 gage (only) wire ends must be tinned with solder before connection at the screw terminals.

MAINTENANCE

GENERAL

This section describes routine maintenance for the Avtron AV850 Encoder. For support, contact field service for Avtron Encoders at 216-642-1230. For emergency after hours service contact us at 216-641-8317. The AV850 SMARTach III circuitry includes a diagnostic package that includes Adaptive Electronics and a Fault-Check output.

ADAPTIVE ELECTRONICS

A perfect duty cycle consists of a waveform whose "high" and "low" conditions are of the same duration (50%/50%). The AV850 adaptive electronics extends the life of the AV850 by constantly monitoring and correcting duty cycle over time.

FAULT-CHECK

After power-up and the rotor position is checked by the sensor, the Fault-Check LED will turn GREEN.

If the adaptive electronics reach their adjustment limit for any reason, the Fault-Check alarm and LED will notify the drive and operator of an impending failure. The LED will turn RED if the Adaptive Electronics reach their adjustment limit. This output occurs before an actual failure, allowing steps to be taken to replace the unit before it causes unscheduled downtime. Fault-Check annunciation is available as an "alarm" output through the connector and as an integral LED.

TROUBLESHOOTING:

If the drive indicates a loss of encoder/tach fault and the AV850 fault-check LED is not illuminated, check the encoder power supply. If power is present, check polarity; one indicator of reversed power supply is that all outputs will be high at the same time. If the drive indicates encoder fault, but the LED shows GREEN, then check the wiring between the drive and the encoder. If the wiring appears correct and in good shape, test the wiring by replacing the AV5 sensor module. If the new module shows GREEN, and the drive still shows encoder loss/tach fault, then the wiring is faulty and should be repaired or replaced.

If the alarm output and/or LED indicate a fault (RED):

1. Remove a sensor plate or one of the sensors, and use the built-in gauge to check the location of the rotor (see Figure 2.1). Ensure the label marked "This side out" is facing away from the motor.
2. Remove the AV5 sensor from the housing. Clean the housing mounting surface for the AV5 sensor and the AV850 housing. Ensure the AV5 sensor is directly mounted on the AV850 housing, with no sealant, gasketing, or other materials, and that it is firmly bolted in place.

ROTOR ALIGNMENT GROOVE

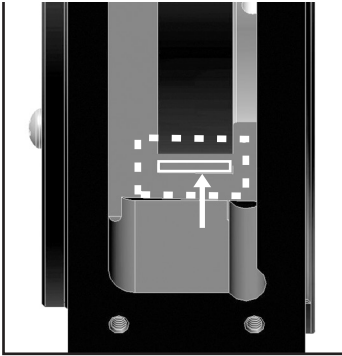

Figure 2.1

Rotor magnetic strip aligns with groove.

If the alarm output and/or LED indicate a fault (RED) on a properly mounted AV5 sensor and the rotor is properly located, replace the AV5 sensor.

An oscilloscope can also be used to verify proper output of the AV850 encoder at the encoder connector itself and at the drive/controller cabinet. If the outputs show large variations in the signals at steady speed (jitter or "accordion effect", see figure 9), check rotor position. If the rotor position is correct, the motor or shaft may be highly magnetized. Replace any magnetized material nearby with non-magnetic material (aluminum, stainless) (shafts, etc). For GE CD frame motors and similar styles, Avtron offers non-magnetic stub shafts (included with all "U" style rotor kits). If variations persist, consider replacing the sensors with super-shielded models, option -004.

If the alarm output and/or LED indicate a wiring fault (ORANGE):

Remove all output wires/connections (A, \bar{A} , B, \bar{B} , Z, \bar{Z}). The LED should turn GREEN. If the LED does not turn GREEN, the encoder is not receiving enough voltage at +V to properly operate. Correct input voltage problem at power supply or cabling.

If the LED turns GREEN once all outputs are disconnected, reconnect each output, one at a time, monitoring for ORANGE LED. For partial/resistive short circuits, the LED may take a few minutes to turn ORANGE. To speed the troubleshooting process, if possible, spin the encoder while replacing individual output connections. This may make the ORANGE LED condition occur faster. Once the shorted output(s) are located, correct the shorting condition, and the encoder LED should remain GREEN.

If the LED is OFF, but power is being applied to the encoder, check the output voltage level at A, \bar{A} , B, \bar{B} . If all outputs are ON ($\approx +V$), the connections to +V and COM are reversed. Swap connections between +V and COM; the LED should turn GREEN.

STATOR HOUSING REMOVAL

To remove the stator housing remove the qty 4 1/2 13 x 3" bolts holding the housing to the motor.

CAUTION

Take care that the housing does not fall from the pilot and cause the sensors to crash into the rotor. Damage to the sensor or rotor could result.

ROTOR REMOVAL

Remove shaft rust and burrs before removing the rotor.

CAM SCREW ROTOR REMOVAL

Disengage the (2) cam screws by turning the left screw clockwise and the right screw counterclockwise less than 1 full turn. The cam heads will visibly move away from the shaft. Remove the rotor by hand by pulling it away from the motor. If the rotor will not move, do NOT use a gear puller, and do not use a heat gun. Instead, insert two M6 screws, >25mm length into the Jack Screw Holes shown in Fig 2.2. Alternately tighten the screws to push the rotor away from the motor and remove it.

LARGE BORE SET SCREW ROTOR REMOVAL

Disengage the (2) set screws by turning the left screw clockwise and the right screw counterclockwise until removed from the rotor. Retain the set screws. Remove the rotor by hand by pulling it away from the motor. If the rotor will not move, do NOT use a gear puller, and do not use a heat gun. Instead, pry the rotor away from the motor gently, being careful to only pry against the rotor metal hub and not the magnetic outer strip.

NOTE

Do not remove the cam screws from the rotor.

RENEWAL AND SPARE PARTS

See Tables 2, 3, and 4.

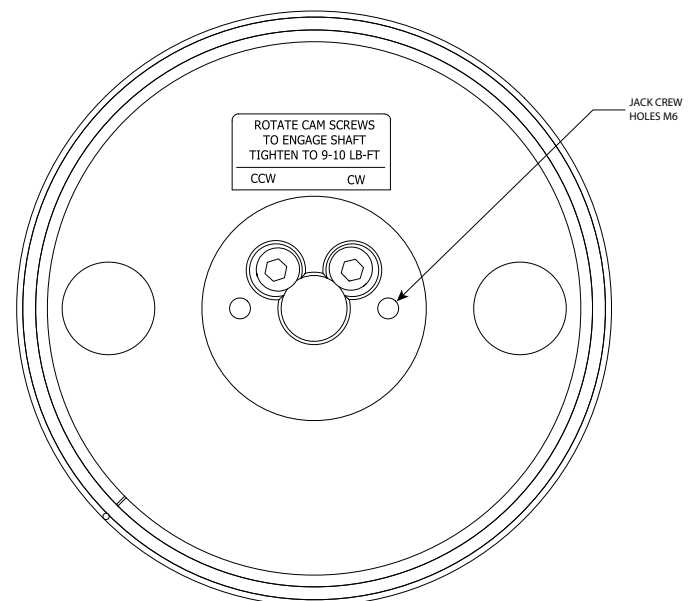

Figure 2.2

SPECIFICATIONS

ELECTRICAL**

- A. Operating Power (Vin)
 - 1. Volts.....5-24 VDC
 - 2. Current100mA, nominal, no load
- B. Output Format
 - 1. 2Ø & CompA, \bar{A} , B, \bar{B} (differential line driver)
 - 2. Marker1/Rev, Z, \bar{Z}
- C. Signal TypeIncremental, Square Wave, 50 ±10% Duty Cycle.
- D. Direction SensingØA leads ØB for CW rotation as viewed from the back of the tach looking at the non-drive end of the motor.
- E. Phase Sep.15% minimum
- F. Frequency Range.....@5V, @1m cable, 250 kHz Max
@24V, @300m cable, #8 output, 45 kHz Max
- G. PPR.....4-50000***
- H. Line Driver Specs.....See table
- I. ConnectorsSee connector options on page 1
- J. LED Indicator.....GREEN: power on, unit ok.
RED: alarm on
ORANGE: wiring fault (Thermal Overload; Under-voltage)

MECHANICAL

- A. Rotor Inertia:.....0.12-0.41 Oz. In. Sec.²
- B. Acceleration:.....5000 RPM/Sec. Max.
- C. Speed:.....6000 RPM Max.****
- D. Weight:.....2-3 lbs [0.9kg to 1.36kg].
- E. Sensor to Rotor
 - Air Gap (nominal):.....0.045" [1.14mm]
 - Tolerance:-0.030"/+0.015" [-0.76mm/+0.38]
- F. Rotor Axial Tolerance.±0.050" [±1.27mm]

ENVIRONMENTAL

Solid cast aluminum stator and rotor
Fully potted electronics, protected against oil and water spray
Use "W" cable option on IP66/67 applications

V-Ring seals provided on through shaft covers
Operating Temperature:.....-40 to 100°C, 0-100% condensing humidity
Vibration: 18 g's
Shock: 1 meter drop test

LINE DRIVER OPTIONS

Electrical Specifications		LINE DRIVER OPTIONS			
		6	8	9	Units
Input Voltage		5-24	5-24	5-24	VDC
Nom Output Voltage		5-24	5-24	5	VDC
Line Driver		7272	Hx	7272	
Output Resistance Typ		13	75	13	ohms
Maximum Peak Current		1500	800	1500	mA
Maximum Average Current		120	200	120	mA
Voh Typ		V _{IN} -1	V _{IN} -1	V _{IN} -1	VDC
Vol Typ		0.5	0.2 @ 10mA line current	0.5	VDC
Cable Drive Capacity		1000' @ 5V 500' @ 12V 200' @ 24V	1000'	1000'	feet
Protection	Reverse Voltage	yes	yes	yes	
	Short Circuit	yes	yes	yes	
	Transient	yes	yes	yes	
	Power to A, Gnd to A/	yes	yes	yes	
Alarm	+V(out)	Output voltage equal to input voltage.			
	Alarm*	Open collector, normally off, goes low on alarm, sink 100mA max, 50VDC max			
	LED	Green=power on, Red=Alarm Orange=Wiring Error (Thermal Overload; Under-voltage)			
Marker		One per revolution. Pulse width approximately 2° (1/128 of a revolution)			

* Alarm not available on connector option "G" (Northstar™ compatible pinout)
** Electrical specifications for SMARTach III model (rev BA or later), consult Nidec Industrial Solutions for earlier model specifications.
***(PPR) Standard maximum PPR is 5000. Consult Factory with your application for PPRs up to 50,000.
**** (Speed) Maximum RPM may be limited for PPR > 2,500. Consult Factory with your application.

WIRING DIAGRAMS

FIGURE 6

FOR DIFFERENTIAL APPLICATIONS

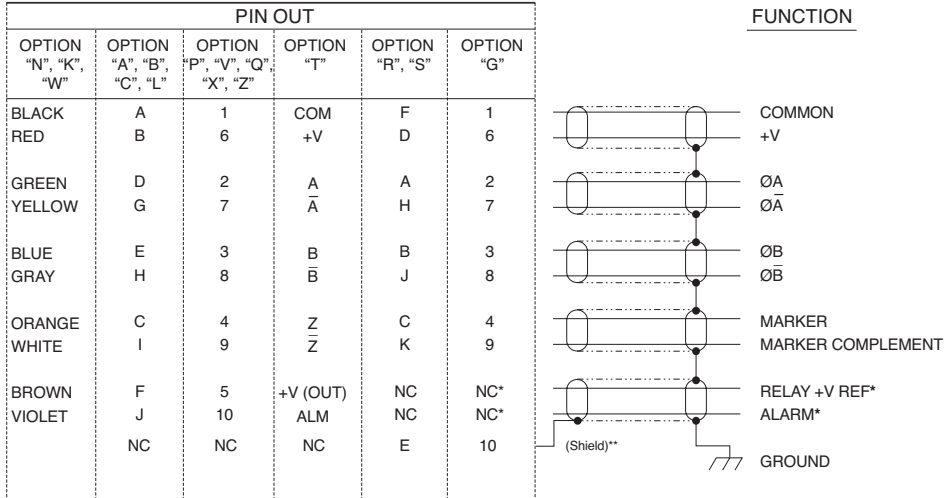

FOR SINGLE ENDED APPLICATIONS

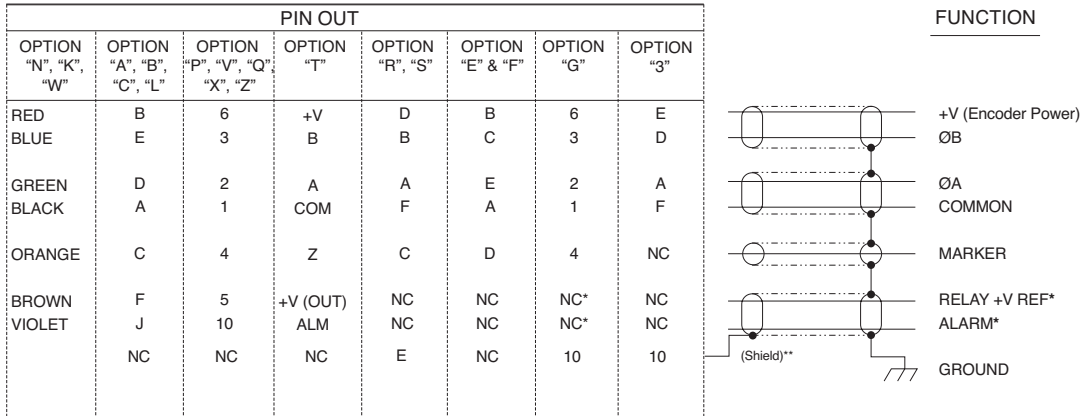

FOR SINGLE ENDED SINGLE PHASE WIRING APPLICATIONS

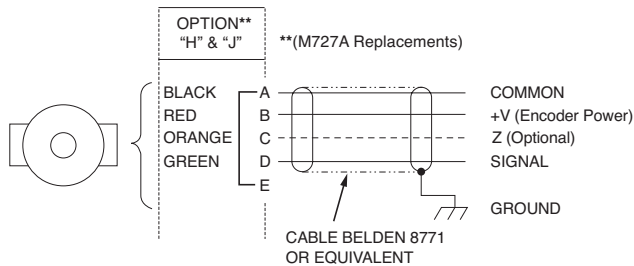

TYPICAL WIRE SELECTION CHART
for 18 AWG, multiple pair, individually shielded

	BELDEN	ALPHA
2 PAIR	9368	6062
3 PAIR	9369	6063
4 PAIR	9388	6064
6 PAIR	9389	6066

* See Figure 7 page 6 for examples of alarm output wiring.

** Avtron recommends shield grounding at drive end. Shield pin does not ground the shield.

SMARTach III™

Application Examples

Applies to all Model AV850 Encoders except connector styles "E", "F", "G", "H", "J", "R", "3".

ALARM OUTPUT CONNECTION

Avtron SMARTach III encoders provide an alarm signal if maintenance is required under specific circumstances. A green LED indicates power on and proper operation, red indicates alarm on. Following are application examples provided to help install the alarm output.

Example 1. Alarm output using +V(OUT). +V(OUT) is equal to +V, the encoder power supply.

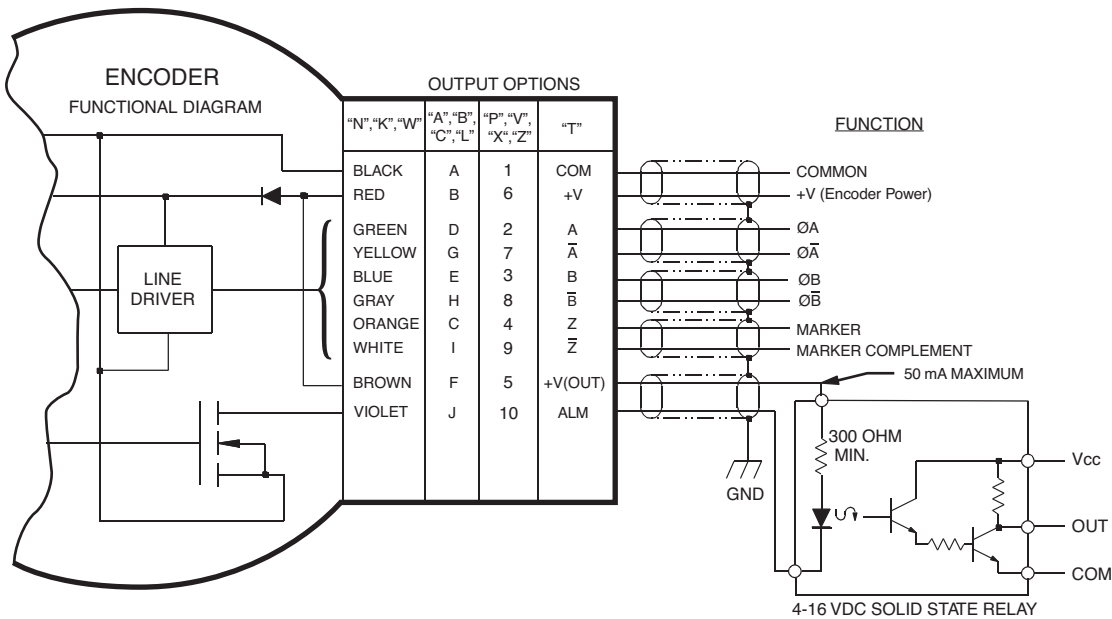

Example 2. Alarm Output Using Separate 24 VDC Power Supply and Relay.

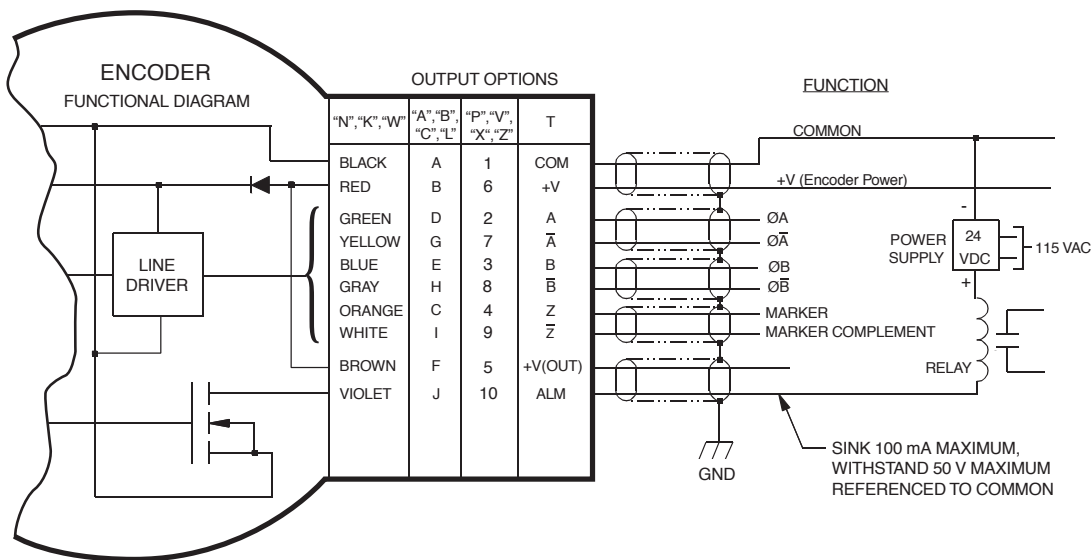

Note: Alarm output is "low true" ; i.e. it goes to 0V when activated

Table 3

SPARE END OF SHAFT ROTORS								
Motor Frame	Motor Specific Style			Universal Style				
	Code	Rotor	Shaft Grounding Kit	Code	Rotor	Shaft Adapter**	Shaft Ground Kit	Magnetic Shield
Universal rotor only* (no stub shaft)	-NA-	-NA-	-NA-	CB*	B31515	none	-NA-	-NA-
CD 180-32x	EF/HF	B30916-EF	A34137	QF/UF/GF	B31515	B31516	A34396	A35355
CD36x	EN/HN	B30916-EN	A34138	QN/UN/GN	B31515	B31517	A34397	A35355
CD4xx	EP/HP	B30916-EP	A34139	QP/UP/GP	B31515	B31518	A34397	A35355
CD444/CD505E	EQ/HQ	B30916-EQ	-NA-	QQ/UQ/GQ	B31515	B31631	A34397	A35355
CD43xx, 44xx, 54xx, 64xx, 65xx		-NA-	-NA-	QV/UV/GV	B31515	B31676	A34397	A35355
CD45xx, 75xx, 76xx		-NA-	-NA-	QW/UW/GW	B31515	B31676	A34397	A35355
CD46xx, 47xx, 85xx, 86xx		-NA-	-NA-	QY/UY/GY	B31515	B31677	A34397	A35355
CD68x		-NA-	-NA-	QZ/UZ/GZ	B31515	B31678	A34397	A35355
CD5xx (excluding CD505)	E2/H2	B30916-E2	A34140	Q2/U2/G2	B31515	B31519	A34397	A35355
E9- CD60xx, 61xx, 62xx, 67xx, 68xx, 69xx	E9/H9	B31092	A34141	Q9/U9/G9	B31515	B31520	A34397	-NA-
All except CD505 and CD680	-NA-	-NA-	-NA-	UU	B31515	B31516, B31517, B31518, B31637, B31676, B31677	-NA-	-NA-

** Shaft adapter part numbers for rotor style "Q" (stacked encoders) is the same as above but with a "-1" suffix.

Table 4

SPARE THROUGH SHAFT ROTORS AND COVERS										
Through Shaft Rotors					Outboard Covers			Inboard Covers		
Shaft Bore	Set Screw		Cam Screw		Flat	Thru-Shaft Cover	Seal ONLY		Seal ONLY	Magnetic Shield
Imperial (US) Sizes	Rotor Code	Rotor Part	Rotor Code	Rotor Part						
0.750"	TA	B30915-TA	CA	B31514-CA	B30934	A34203-2	471908	-NA-	-NA-	A35355
0.625"	TB	B30915-TB	CB*	B31515		A34203-1	471814	A26211-1	471814	A35355
0.875"	TC	B30915-TC	CC	B31514-CC		A34203-3	471931	-NA-	-NA-	A35355
3.625"	TD	B30915-TD	-NA-	-NA-		-NA-	-NA-	-NA-	-NA-	-NA-
1.000"	TE	B30915-TE	CE	B31514-CE		A34203-4	471900	A26211-2	471900	A35355
1.125"	TF	B30915-TF	CF	B31514-CF		A34203-5	471873	A26211-3	471873	A35355
3.750"	TG	B30915-TG	-NA-	-NA-		-NA-	-NA-	-NA-	-NA-	-NA-
1.375"	TH	B30915-TH	CH	B31514-CH		A34203-7	471884	A26211-4	471884	A35355
1.625"	TJ	B30915-TJ	CJ	B31514-CJ		A34203-8	471901	A26211-5	471901	A35355
1.750"	TK	B30915-TK	CK	B31514-CK		A34203-10	471902	-NA-	-NA-	A35355
1.875"	TL	B30915-TL	CL	B31514-CL		A34203-11	471902	A26211-6	471902	A35355
2.000"	TM	B30915-TM	CM	B31514 CM		A34203-12	471886	A26211-7	471886	A35355
2.125"	TN	B30915-TN	CN	B31514-CN		A34203-13	471903	A26211-8	471903	A35355
2.375"	TP	B30915-TP	CP	B31514-CP		A34203-15	471904	A26211-12	471904	A35355
2.250"	TQ	B30915-TQ	CQ	B31514-CQ		A34203-14	471903	A26211-8	471903	A35355
2.500"	TR	B30915-TR	CR	B31514-CR		A34203-16	471905	A26211-9	471905	A35355
2.625"	TT	B30915-TT	CT	B31514-CT		A34203-25	471905	-NA-	-NA-	A35355
3.250"	TW	B30915-TW	CW	B31514-CW		A34203-19	471907	-NA-	-NA-	-NA-
3.375"	TY	B30915-TY	CY	B31514-CY		A34203-20	471906	-NA-	-NA-	-NA-
3.421"	TZ	B30915-TZ	CZ	B31514-CZ		A34203-21	471906	-NA-	-NA-	-NA-
4.000"	T1	B30915-T1	-NA-	-NA-		-NA-	-NA-	-NA-	-NA-	-NA-
2.875"	T2	B30915-T2	C2	B31514-C2	↓	A34203-17	471885	A26211-10	471885	A35355
3.500"	T3	B30915-T3	C3	B31514-C3		A34203-22	471910	A26211-11	471910	-NA-
3.875"	T4	B30915-T4	-NA-	-NA-		A34203-23	471943	-NA-	-NA-	-NA-
4.500"	T6	B30915-T6	-NA-	-NA-		A34203-24	-NA-	-NA-	-NA-	-NA-
Metric Sizes	Set Screw		Cam Screw							
30mm	MF	B31502-MF	-NA-	-NA-	B30934	A34203-6	471939	-NA-	-NA-	A35355
42mm	MJ	B31502-MJ	-NA-	-NA-	↓	A34203-9	471901	-NA-	-NA-	A35355
60mm	MP	B31502-MP	-NA-	-NA-		A34203-15	471904	-NA-	-NA-	A35355
80mm	MY	B31502-MY	-NA-	-NA-		A34203-18	471907	-NA-	-NA-	-NA-
80mm	MZ	B31502-MZ	-NA-	-NA-	↓	A34203-18	471907	-NA-	-NA-	-NA-
90mm	M3	B31502-M3	-NA-	-NA-		-NA-	-NA-	-NA-	-NA-	-NA-
95mm	M4	B31502-M4	-NA-	-NA-		A34203-26	471550	-NA-	-NA-	-NA-
70mm	M5	B31502-M5	-NA-	-NA-		-NA-	-NA-	-NA-	-NA-	-NA-

* Note Universal rotor (CB) is a 5/8" thru-shaft cam screw style rotor. Universal style kits (GF-G9, QF-Q9, UF-U9) add the required stub shaft to fit the rotor to GE CD frame motors.

ADDITIONAL CONNECTOR OPTIONS

FIGURE 8

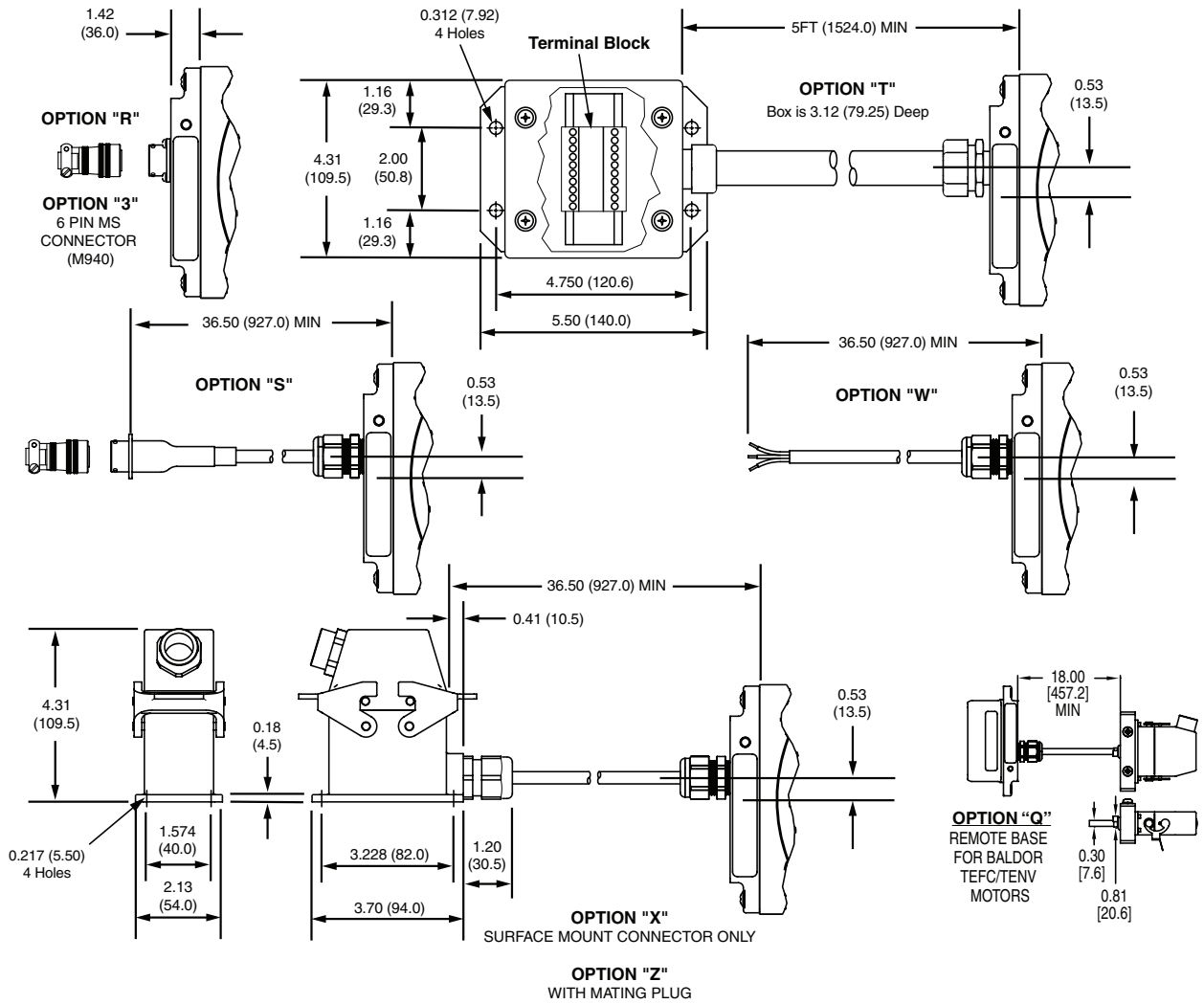

Dimensions in parenthesis are in millimeters.
All dimensions are approx.

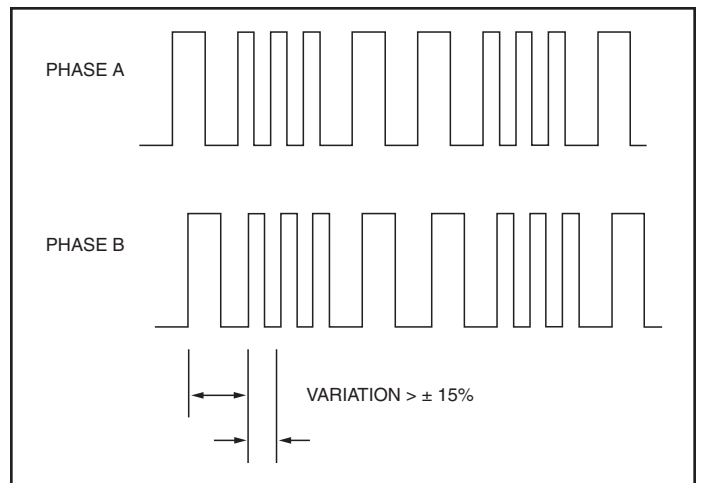
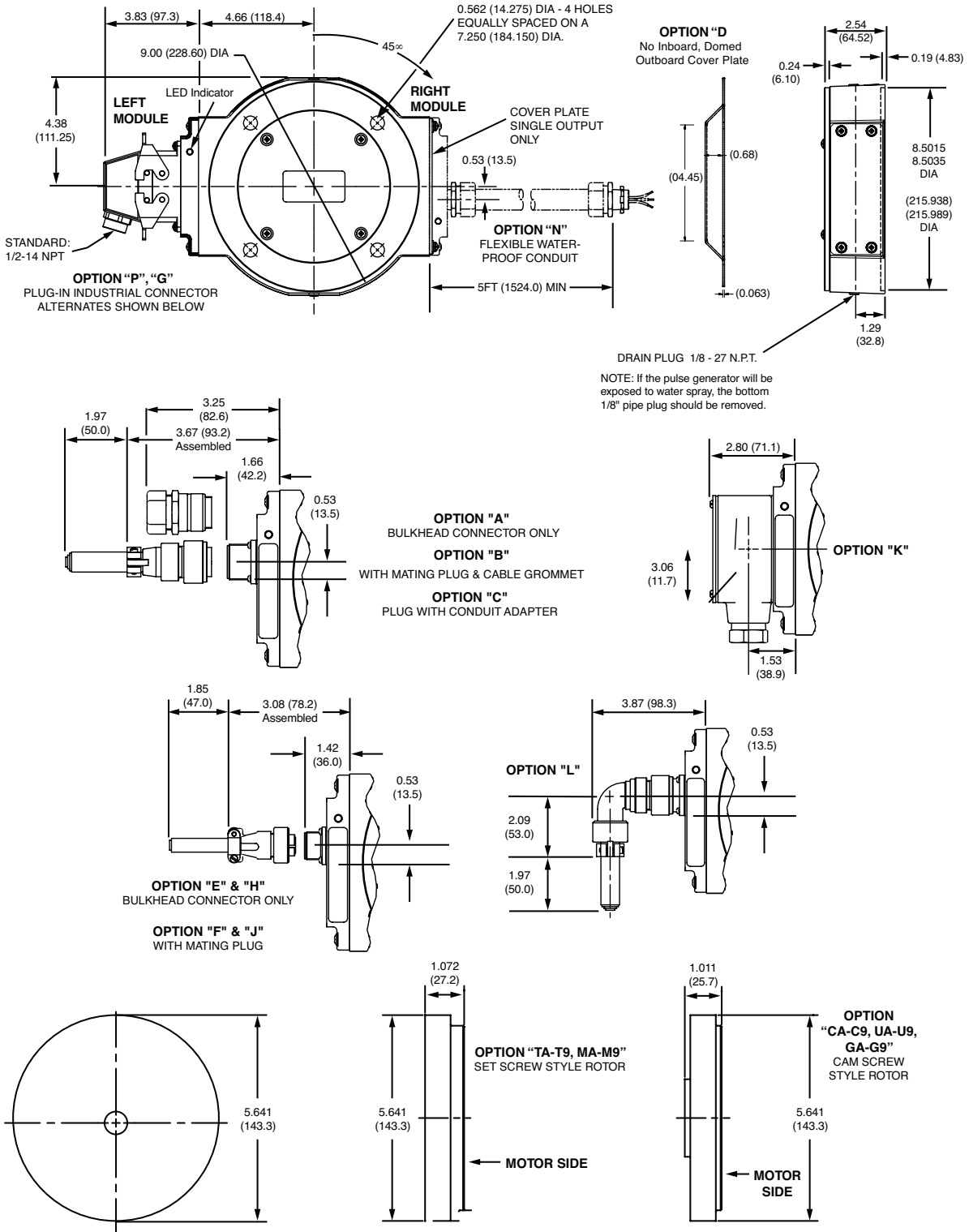

FIGURE 9 Excessive Signal Variation ("Jitter")

OUTLINE DIMENSIONS AND OPTION DETAILS

For additional wiring options see Figure 8.

FIGURE 10



SMARTach™ III is a trademark of Nidec Industrial Solutions, Inc.
Features and specifications subject to change without notice.
Avtron Encoder standard warranty applies. All dimensions are in inches (mm).



Avtron Encoders are the Most Reliable Encoders in the World

Nidec Industrial Solutions
8901 E. Pleasant Valley Road • Independence, Ohio 44131-5508
E-mail: helpdesk@nidec-industrial.com • Web: www.avtronencoders.com
Phone: (216) 642-1230 • Fax: (216) 642-6037

REV DATE: 05/02/2020

REV: 003