

AVTRON™ ENCODERS

Nidec Makes the Most Reliable Encoders in the World

Nidec Industrial Solutions
 243 Tuxedo Avenue | Cleveland, Ohio 44131
 encoderhelpdesk@nidec-industrial.com - www.avtronencoders.com
 +1 216-642-1230

Encoder Instructions

HS35M

1/2" to 1 1/8" [12mm-30mm]
 HOLLOW SHAFT

DESCRIPTION

The Avtron Model HS35M Magnetic Hollow Shaft Incremental Encoder is a speed and position incremental transducer (also known as a tachometer or pulse generator). When mounted to a motor or machine, its output is directly proportional to shaft position (pulse count) or speed (pulse rate). The HS35M operates down to zero speed and can be used for both control and instrumentation applications.

The HS35M employs a hollow shaft and clamping or end-of-shaft center-bolt to secure the encoder to the shaft. A high-performance resin housing provides electrical isolation from motor shaft currents. An optional hollow shaft insert permits 1" models to fit a broad range of shaft sizes from 1/2" to 1" [12mm - 20mm]; 1 1/8", 25mm, and 30mm dedicated models are available. An anti-rotation bracket prevents rotation of the encoder while allowing for shaft end float and axial movement. Center bolt mounting style is also available in 16mm straight and 17mm 10:1 taper configurations.

Equipment Needed for Installation

Provided	Optional	Not Provided
- HS35M Encoder with Clamping Collar or Center Bolt	- Anti-Rotation Tether Kit - Shaft Sizing Insert - Mating MS or EPIC - Industrial Cable - Connector/Plug - Protective Basket Kit (Part #: A32920) - Anti-Seize (Copper) - Thread Locker (Blue)	- #2 Phillips Screwdriver - 3/16" Hex Wrench (US) 4mm - Hex Wrench (Metric) - (T-Handle Style) - Caliper Gauge - Dial Indicator Gauge - 7/16", 9/16", 5/8", 3/4" - Wrenches (tether options) - M5 T-Handle Hex Wrench or Torque Wrench

The HS35M encoder offers 2Ø outputs (A,B) 90° apart for direction sensing, with complements (Ā,B̄) and with marker pulse and complement (Z,Z̄).

HS35M PART NUMBERS AND AVAILABLE OPTIONS

Model	Left & Right Output PPR	Line Driver	Bore Size	Connector Options	Mounting Style	Protection	Anti-Rotation Tether Options	Channels	Special Features
HS35M	F- 60 T- 80 G- 100 H- 120 K- 200 L- 240 M-250 N- 256 P- 300 E- 360 Q- 500 R- 512 S- 600 U- 720 V- 900 W-1000 Y- 1024	Z- 1200 1- 1250 2- 1440 B- 1500 3- 2000 4- 2048 5- 2500 C- 3072 X- None (NA for left output) 0- Special "See Table"	6- 5-24V (7272) 8- 5-15V (4125) 9- 5-24V in, 5V out (7272)	0- Non-Std. S- 16mm V- 19mm B- 1/2" W- 20mm C- 5/8" Y- 25mm* D- 3/4" 3- 30mm* E- 7/8" 6- 16mm* F- 1" EOS (Straight) G- 1 1/8" 7- 17mm* P- 12mm EOS (10:1 Taper) Q- 14mm R- 15mm P- 12mm	W- 18" flex. cable U- Universal End-of-Shaft & Thru Shaft	0- None 1- Basket**	X- None A- Fan cover, 1/4-20 B- Fan cover, 5/16-18 C- Fan cover, 3/8-16 D- Fan cover, all E- 4.5" or 6.75" C-Face F- 8.5" C-Face G- 12" [300mm] Threaded Rod Tether M- 4.5" C-Face or Fan Cover U- Universal (all tether options, excluding "G") P- 4.5" [115mm] Threaded Rod Tether, replaces Northstar HS35M, HSD35 T- Torque Arm: M6x 76mm Long	A- A,Ā,B,Ḃ,Z,Z̄ B- A,Ā,B,Ḃ D- A,Ā E- A,B,Z F- A,B J- All Signals A,Ā,B,Ḃ,Z,Z̄, 1/4- Pulse Marker to A- high/B-High 4- Special PPR Enter codes under special features 9- All. Enter specific cable length xx=feet under Special Features (Use w/ Connector Option "W").	00- None 0W- Connector on 18" cable: See Below

Connector Options

Terminal Box	Mounted on Encoder					Mounted on 18" cable (0W)					
	M23 12-Pin	10 Pin MS	10 Pin EPIC	10 Pin mini MS	10 Pin MS<	6 Pin MS<	7 Pin MS<	8 Pin M12<	10 Pin EPIC<	10 Pin mini MS<	12 Pin M23
5- w/ 10 pin push-in terminal block	4- Rt Angle w/o plug	A- w/o plug (std. phasing) B- w/o plug (Dynapar HS35 phasing) C- "A" w/ plug D- "B" w/ plug	P- w/ plug V- w/o plug	R- w/ plug	Y- w/o plug	E- w/o plug (std. phasing) F- w/o plug (Dynapar HS35 phasing) G- "E" w/ plug H- "F" w/ plug	J- w/o plug (std. phasing) K- w/o plug (Dynapar HS35 phasing) M- "J" w/ plug N- "K" w/ plug	T- w/o plug (Turck Pinout) U- w/o plug (US Pinout)	Z- w/ plug	S- w/ plug	2- w/o plug (L&L Hubner pinout)

SPECIAL PPR OPTION CODES

OPTION CODE	LEFT PPR	RIGHT PPR
401	1270	None
402	150	None
403	50	None
404	512	16
405	16	None
406	6000	None
407	2800	None
408	1400	None
409	30	None

INSTALLATION CONSIDERATIONS

See page 3 and drawing on last page for shaft engagement rules. Shaft may include keyway, but should not be flatted. The HS35M offers optional Avtron flexible anti-rotation tethers/brackets which will permit the encoder to tolerate ±0.1" of shaft end float/axial movement. For larger movement, select tether option "G" from the table below.

CAUTION

Be careful not to damage clamping fingers of hollow shaft during handling. Do not tighten clamping collar before installation onto motor shaft.

WARNING

Installation should be performed only by qualified personnel. Safety precautions must be taken to ensure machinery cannot rotate and all sources of power are removed during installation.

WARNING

DO NOT USE ANAEROBIC THREAD LOCKER COMPOUNDS ON THE HS35M. Use of Loctite 222, 242 or other anaerobic thread locking compounds on the housing can cause failure of the HS35M housing.

INSTALLATION

Refer to the back page of these instructions for outline and mounting dimensions. Also available: EU (European Union) Installation Sheet, Torque Arm Installation Sheet, and Basket Mount Installation Sheet.

NOTE

For metric bore sizes, the encoder is provided with metric size hardware. For US bore sizes, the encoder is provided with US size hardware.

The hollow shaft HS35M design eliminates the potential for coupling failures from misalignment, however, excessive housing movement (wobble) may cause undesirable vibrations and bearing damage. The higher the RPM, the more severe the vibration will be from housing

movement. In a typical installation a housing movement of 0.007" [0.18mm] TIR or less (as measured at the outside diameter of the main encoder body) will not have an adverse effect. For overspeed applications, TIR should be <0.002" [0.05mm].

- 1) Disconnect power from equipment and encoder cable.
- 2) Use caliper gauge to verify motor shaft is proper diameter and within allowable tolerances: +0.000", -0.0005" [+0.00, -0.13mm].
- 3) Clean machine shaft of any dirt and remove any burrs.
- 4) Use dial indicator gauge to verify the motor shaft Total Indicated Runout (TIR) <0.002" [0.05mm].
- 5) Install the anti-rotation bracket to the face of the encoder using 8-32 screws and lock washers.

For clamp collar mounting style:

- 6) Loosen clamping collar screws.

NOTE

These screws have factory applied thread locker, no further thread locker application is required.

- 6) Optional: for resizing HS35M 1" bore to fit smaller diameter shafts: Insert shaft sizing insert into encoder. **DO NOT FORCE.**
- 7) Test Fitting: carefully slide the encoder onto the shaft to verify fit. Ensure a minimum of 1/8" between encoder and mounting surface. **DO NOT FORCE.** Encoder should slide on easily. If the encoder does not fit easily, remove it, verify shaft size, and check for burrs and shaft damage.
- 8) Special Note for shaft in HS35M without a shaft insert ONLY: Remove encoder, apply anti-seize compound to shaft and reinstall encoder, leaving a minimum of 1/8" between motor face and encoder (see "Shaft Engagement").

SPECIFICATIONS

ELECTRICAL

- A. Operating Power (Vin)
 1. Volts..... See Line Driver Options
 2. Current 80mA, no load
- B. Output Format A Quad B with marker (A, \bar{A} , B, \bar{B} , Z, \bar{Z}) "J Option" All Signals A, A, B, B, Z, Z, 1/4-Pulse Marker to A-High/B-High
- C. Signal Type Incremental, Square Wave, 50% ±10% Duty Cycle
- D. Direction Sensing Phasing with respect to rotation as viewed from the back of the encoder.
 - Connector options "A", "C", "E", "G", "J", "M", "P", "R", "S", "U", "V", & "W" ØA leads ØB for CW rotation.
 - Connector options "B", "D", "F", "H", "K", "N", "T" ØA leads ØB for CCW rotation.
- E. Transition Separation 15% minimum
- F. Frequency Range 0 to 165 kHz.
- G. PPR1 - 3072 standard (for other PPR needs, Consult Factory)
- H. Output See Line Driver Options

MECHANICAL

- A. Acceleration..... 4,700 RPM/Sec.
- B. Speed..... 4,700 RPM max. (for higher RPM needs, Consult Factory)
- C. Shaft Diameter..... 0.500" to 1.125" [12mm to 30mm]
- D. Shaft Engagement..... 1.250" to 2.250" [32mm-57mm] End-of-Shaft*
 - *1.750" to 2.250" with sizing inserts Unlimited Thru Shaft
- E. Weight..... Single: 1.4 lbs. [635 g] approx. Dual: 2.0 lbs. [905 g] approx.

ENVIRONMENTAL

- A. Enclosure Rating NEMA 13, IP65 (dust and water tight, not for immersion)
- B. Operating Temp. -20° to +85°C
- C. Humidity..... 98% Non-condensing
- D. Shock 50G, 11 ms Duration
- E. Vibration..... 5-2000Hz @ 20G

LINE DRIVER OPTIONS

		Output Options		
		6	8*	9
Output Type	Differential Line Driver	High Current Line Driver	Differential Line Driver 5V output	
Line Driver	7272	Hx	7272	
Voltage Input (Vin)	5-24VDC	5-15VDC	5-24VDC	
Voltage Output (Vout)	5-24V	5-15V	5V (Fixed)	
Protection	Reverse Voltage	Yes	Yes	Yes
	Transient	Yes	Yes	Yes
	Short Circuit	Yes	Yes	Yes

* Line Drivers Option "8" employs "4125" chip on units prior to REV_BR and Hx" chip on units of Rev_BR and higher



- 9) Tighten screws on clamping collar evenly until snug, then tighten each screw to 35-50 in-lb [4-6 Nm]. **DO NOT USE A STANDARD RIGHT ANGLE WRENCH.** Use only a T-handle hex wrench or torque wrench with hex bit. Note: Units shipped with a metric bore size require a 4mm T-handle hex wrench; units with US size bores, a 3/16" T-handle hex wrench.
- 10) For all motor mount options other than 8.5" C-face: Snap the plastic washer pair together in the mounting slot of the anti-rotation arm. (See assembly diagram on page 4 for full details)
- 11) Secure free end of the anti-rotation bracket to frame using bolt or T-bolt provided. Use additional washers as needed to install the bracket without a large deflection or bend.
- 12) Turn shaft by hand and verify the shaft turns freely and does not produce excessive runout/wobble of the encoder (<0.005" TIR [0.13mm], Total Indicator Reading).
- 13) Connect cable as shown in wiring diagram.
- 14) Apply power to the encoder.
- 15) Rotate the shaft by hand, or using jog mode of the speed controller and verify proper direction.

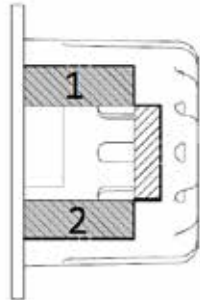

- 16) Optional Protective Basket: Install protective basket using either the T-bolts (fan cover) or bolt to 4.5" C-Face (bolts provided). Break out section 1 and 2 (see illustration) on protective basket. Be certain to pivot the basket over the encoder connector when installing. Be certain that the protective basket does not touch or interfere with the anti-rotation arm/bracket.

To mount the basket on an 8.5" C-Face: DO NOT FORCE. Thread the 1/2"-13 bolts into the motor face, through each clip (provided with options "F" and "U") but do not tighten fully. Pivot the basket over the encoder and pivot each clip over each respective basket bolt hole. DO NOT FORCE. Tighten each bolt to secure the basket and clip.

NOTE: Order Part #: A32920 for protective basket gaurd and all tethers.

For End of Shaft Center Bolt Mount Style:

- 6) Remove the rear cap from the HS35M Encoder.
- 7a) For 17mm taper shaft mount: Carefully slide the encoder onto the shaft to verify fit. DO NOT FORCE. Encoder should slide on easily. If the encoder does not fit easily, remove it, verify shaft size, and check for burrs and shaft damage.
- 7b) For 16mm center bolt shaft mount: Slide the centering ring over the motor shaft. Carefully slide the encoder onto the shaft to verify fit. DO NOT FORCE. Encoder should slide on easily. If the encoder does not fit easily, remove it, verify shaft size, and check for burrs and shaft damage.
- 8) Insert center mounting screw (M6 provided) through the body of the encoder into the stub shaft tapped hole and tighten to 66 in- lbs [7.5n-m]
- 9a) Replace rear cap onto the HS35M Encoder.
- 10) (For threaded rod tethers only) Adjust to proper length by selecting combinations of short and long piece as required and thread together for final length adjustment. Attach free end of the anti-rotation arm to the bracket tether using the shoulder bolt provided.

- 11) Secure free end of the anti-rotation bracket to motor frame using bolt or T-bolt provided. The bracket should be parallel to the encoder face, 90 degrees to the shaft to avoid encoder bearing damage. Use additional washers as needed to ensure the tether is parallel to the encoder face.
- 12) An M8 threaded hole is provided in the encoder shaft to permit a M8 jack bolt for removal.
- 13) Secure free end of the anti-rotation bracket to motor frame using bolt or T-bolt provided. Use additional washers as needed to install the bracket without a large deflection or bend.
- 14) Turn shaft by hand and verify the shaft turns freely and does not produce excessive runout/wobble of the encoder (<0.005" TIR [0.13mm], Total Indicator Reading).
- 15) Connect cable as shown in wiring diagram.
- 16) Apply power to the encoder.

Adjusting the Encoder to Eliminate Excess Runout/Wobble:

In a typical installation, a housing movement of 0.005" TIR or less (as measured at the outside diameter of the main encoder body) will not have an adverse effect. If excessive housing movement is detected in the installation:

- 1) Disconnect power from equipment and encoder cable.
- 2) Check the shaft the HS35M is mounted on for excessive shaft runout using a dial gauge. NEMA MG1 calls for 0.002" TIR or less.
- 3) Verify that the mounting shaft meets minimum and maximum diameter tolerances.
- 4) Maximize the shaft insertion into the encoder (retaining the minimum of 1/8" between mounting face and encoder)
- 5) Loosen the clamping collar and rotate the motor shaft 180° within the encoder hollow shaft sleeve. Retighten the clamping collar.
- 6) Loosen the clamping collar; move the split in the clamping collar over a solid portion of the encoder shaft, retighten the clamping collar.

If excessive housing movement still exists after the above steps, the shaft or the encoder may be damaged and should be checked by the manufacturer.

Shaft Sizes:

HS35M: 1/2"* , 5/8"* , 3/4"* , 7/8"* , 1"* , 1-1/8" , 12mm* , 15mm* , 16mm* , 20mm* , 25mm , 30mm

NOTE: *HS35M units may utilize shaft insulating resin insert; these models from 0.500" to 1.00" [12mm to 20mm] may be resized as needed by interchanging or removing inserts.

*** HS35M at 1-1/8" , 25mm, and 30mm cannot be resized.**

Consult factory for other shaft sizes not shown.

Shaft Engagement:

HS35M: For end of shaft applications, shaft insertion/engagement should be 1.25" to 2.06" [32mm to 52mm] with a minimum of 1/8" [3mm] between encoder and mounting surface. Minimum insertion/engagement is 1.75" [44mm] for models using a sizing insert. The HS35M may also be used for thru shaft applications by removing the end of shaft cover.

For shaft lengths greater than the maximum engagement allowed, end of shaft mounting may still be employed by using a spacer between the mounting surface and anti-rotation bracket.

lengths (up to 2000 feet typically at 5-15V). All HS35M line drivers have full protection against external faults. These factors may dictate maximum potential cable length.

CAUTION

When inserting shafts to a depth over 2.06" [52mm], be sure to remove the cover to prevent cover contact with the rotating shaft.

WIRING INSTRUCTIONS

CAUTION

Be sure to remove power before wiring the encoder. Be sure to ground the cable shield: It can be connected to case ground at the encoder, or grounded at the receiving device, but should not be grounded on both ends.

The HS35M encoder can be wired for single phase or two-phase operation, either with or without complements, with or without markers. See connector options and wiring diagrams.

CAUTION

When wiring for differential applications (A, \bar{A} , B, \bar{B} , Z, \bar{Z}), A and \bar{A} should be wired using one twisted, shielded pair; B and \bar{B} should be in a second pair, etc. Failure to use complementary pairs (say, using A and B in a twisted pair) will reduce noise immunity significantly.

For encoder output that correctly reflects the direction of rotation, proper phasing of the two output channels is important. Phase A channel leads phase B channel for clockwise shaft rotation as viewed from the back (non-mounting side) of the encoder for standard phasing options ("A", "C", "E", "G", "J", "M", "P", "R", "S", "U", "V", & "W"). Follow instructions under corrective installation as needed to reverse the direction of output or purchase HS35M with reverse (Dynapar HS35) phasing (options "B", "D", "F", "H", "K", & "N").

CORRECTIVE ACTION FOR PHASE REVERSAL

If Encoder Direction is Reversed:

(Note: Avtron offers reverse phasing options for former Dynapar HS35 customers – select wiring option "B" or "D").

- 1) Remove power.
- 2) Exchange wires on cable, either at encoder cable end, or at speed controller end (but not both):
 - a.) Single Ended 2 Phase Wiring (see wiring diagram below)
Exchange A and B at the user end of the wires.
 - b.) Differential 2 Phase Wiring (see wiring diagram below)
Exchange either A with \bar{A} in the phase A pair OR B with \bar{B} in the phase B pair but NOT both.
- 3) Apply power.
- 4) Verify encoder feedback is correct, using hand rotation of shaft, or jog mode of the speed controller.

Interconnecting cables specified in the wire selection chart are based on typical applications. Refer to the "Wiring Diagrams" below for suggested cable types. General electrical requirements are: stranded copper, 22 thru 16 gauge (Connector Option "P" can use 14 AWG), each wire pair individually shielded with braid or foil with drain wire, 0.05 uF maximum total mutual or direct capacitance with outer sheath insulator.

NOTE

When using the industrial connector ("P", "V", or "Z" options), the minimum wire size is 20 gage, and 20 gage (only) wire ends must be tinned with solder before connection at the screw terminals.

*Maximum cable length (and line driver selection) is limited by several factors: line driver protection, maximum RPM, PPR, output voltage and cable capacitance. Line driver option 8 permits the longest cable

HS35M WIRING DIAGRAMS

DIFFERENTIAL TWO PHASE WIRING APPLICATIONS

CONNECTOR		PINOUT									
OPTION "W" (CABLE)	OPTIONS "A", "B", "C", "D" (10 PIN MS)	OPTIONS<< "J", "K", "M", "N" (7 PIN MS)	OPTIONS<< "E", "F", "G", "H" (6 PIN MS)	OPTIONS<< "T" (8 PIN M12)	OPTIONS<< "U" (8 PIN M12)	OPTIONS "P", "V", "Z<<", "5" (10 PIN INDUSTRIAL) "5" (Terminal Box)	OPTIONS "R", "S<<" (10 PIN TWIST-LOCK)	OPTIONS 2, 4 (12 PIN M23)			
A	A, ØA, ØĀ, ØB, ØB̄, ØZ, ØZ̄	B	B	A	A	A	A	A			
	ØA, ØĀ, ØB, ØB̄, ØZ, ØZ̄	ØA, ØĀ, ØB, ØB̄	ØA, ØĀ, ØB, ØB̄	ØA, ØĀ, ØB, ØB̄, ØZ, ØZ̄	ØA, ØĀ, ØB, ØB̄, ØZ, ØZ̄	ØA, ØĀ, ØB, ØB̄, ØZ, ØZ̄	ØA, ØĀ, ØB, ØB̄, ØZ, ØZ̄	ØA, ØĀ, ØB, ØB̄, ØZ, ØZ̄			
BLACK	F	F	A	1	7	1	F	10			
RED	D	D	B	2	2	6	D	12			
GREEN	A	A	E	3	1	2	A	8			
YELLOW	H	C	C	4	3	7	H	1			
BLUE	B	B	D	5	4	3	B	5			
GRAY	I	E	F	6	5	8	J	6			
ORANGE	C	NC	NC	7	6	4	C	3			
WHITE	J	NC	NC	8	8	9	K	4			
BROWN	NC	NC	NC	NC	NC	NC	NC	2			
VIOLET	NC	NC	NC	NC	NC	NC	NC	7			

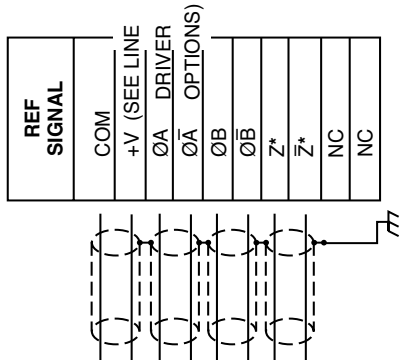

REF SIGNAL
COM
+V (SEE LINE)
ØA DRIVER
ØĀ OPTIONS
ØB
ØB̄
Z*
Z̄*
NC
NC

TYPICAL WIRE SELECTION CHART for 18 AWG, multiple pair, individually shielded

	BELDEN	ALPHA
2 PAIR	9368	6062C
3 PAIR	9369	6063C
4 PAIR	9388	6064C
6 PAIR	9389	6066C

For Connector Option "W", unused connections must be insulated to prevent accidental contact.

* NC ON CHANNEL OPTION "B"
<< CONNECTED ON 18" CABLE

Pinout Options

SINGLE ENDED TWO PHASE WIRING APPLICATIONS, WITH OR WITHOUT MARKER

CONNECTORS		PINOUT							
OPTION "W" (CABLE)	OPTIONS "A", "B", "C", "D" (10 PIN MS)	OPTIONS<< "J", "K", "M", "N" (7 PIN MS)	OPTIONS<< "E", "F", "G", "H" (6 PIN MS)	OPTIONS<< "U" (8 PIN M12)	OPTIONS "P", "V", "Z" (10 PIN INDUSTRIAL)	OPTIONS "R", "S" (10 PIN TWIST-LOCK)			
A ØA, ØĀ ØB, ØB̄ ØZ, ØZ̄	E, F ØA, ØB, ØZ	E, F ØA, ØB, ØZ	E, F ØA, ØB, ØZ	A ØA, ØĀ ØB, ØB̄ ØZ, ØZ̄	A ØA, ØĀ ØB, ØB̄ ØZ, ØZ̄	A ØA, ØĀ ØB, ØB̄ ØZ, ØZ̄ INCLUDED BUT NOT USED			
RED	D	D	B	2	6	D			
BLUE	B	B	D	4	3	B			
GREEN	A	A	E	1	2	A			
BLACK	F	F	A	7	1	F			
ORANGE*	C*	C*	C*	6	4	C			

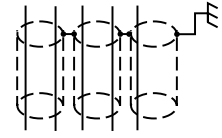
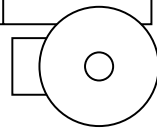

REF SIGNAL
+V (SEE LINE DRIVER OPTIONS)
ØB
ØA
COM
ØZ*

* NC ON CHANNEL OPTION "F"
 ^ COMPLEMENTS INCLUDED BUT NOT USED
 << CONNECTED ON 18" CABLE

SINGLE ENDED SINGLE PHASE WIRING APPLICATIONS

CONNECTORS		PINOUT						
OPTION "W" (CABLE)	OPTIONS "A", "B", "C", "D" (10 PIN MS)	OPTIONS<< "J", "K", "M", "N" (7 PIN MS)	OPTIONS<< "E", "F", "G", "H" (6 PIN MS)	OPTIONS<< "U" (8 PIN M12)	OPTIONS "P", "V", "Z" (10 PIN INDUSTRIAL)	OPTIONS "R", "S" (10 PIN TWIST-LOCK)		
A ØĀ, ØB̄ ØB, ØZ, ØZ̄ INCLUDED BUT NOT USED	D ØA INCLUDED BUT NOT USED	D ØA INCLUDED BUT NOT USED	D ØA INCLUDED BUT NOT USED	A ØĀ, ØB̄ ØB, ØZ, ØZ̄ INCLUDED BUT NOT USED	A ØA, ØĀ ØB, ØB̄ ØZ, ØZ̄ INCLUDED BUT NOT USED	A ØA, ØĀ ØB, ØB̄ ØZ, ØZ̄ INCLUDED BUT NOT USED		
BLACK	F	F	A	7	1	F		
RED	D	D	B	2	6	D		
GREEN	A	A	E	1	2	A		

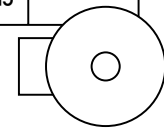

REF SIGNAL
COM
+V (SEE LINE DRIVER OPTIONS)
ØA

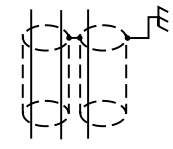

OUTLINE DRAWINGS

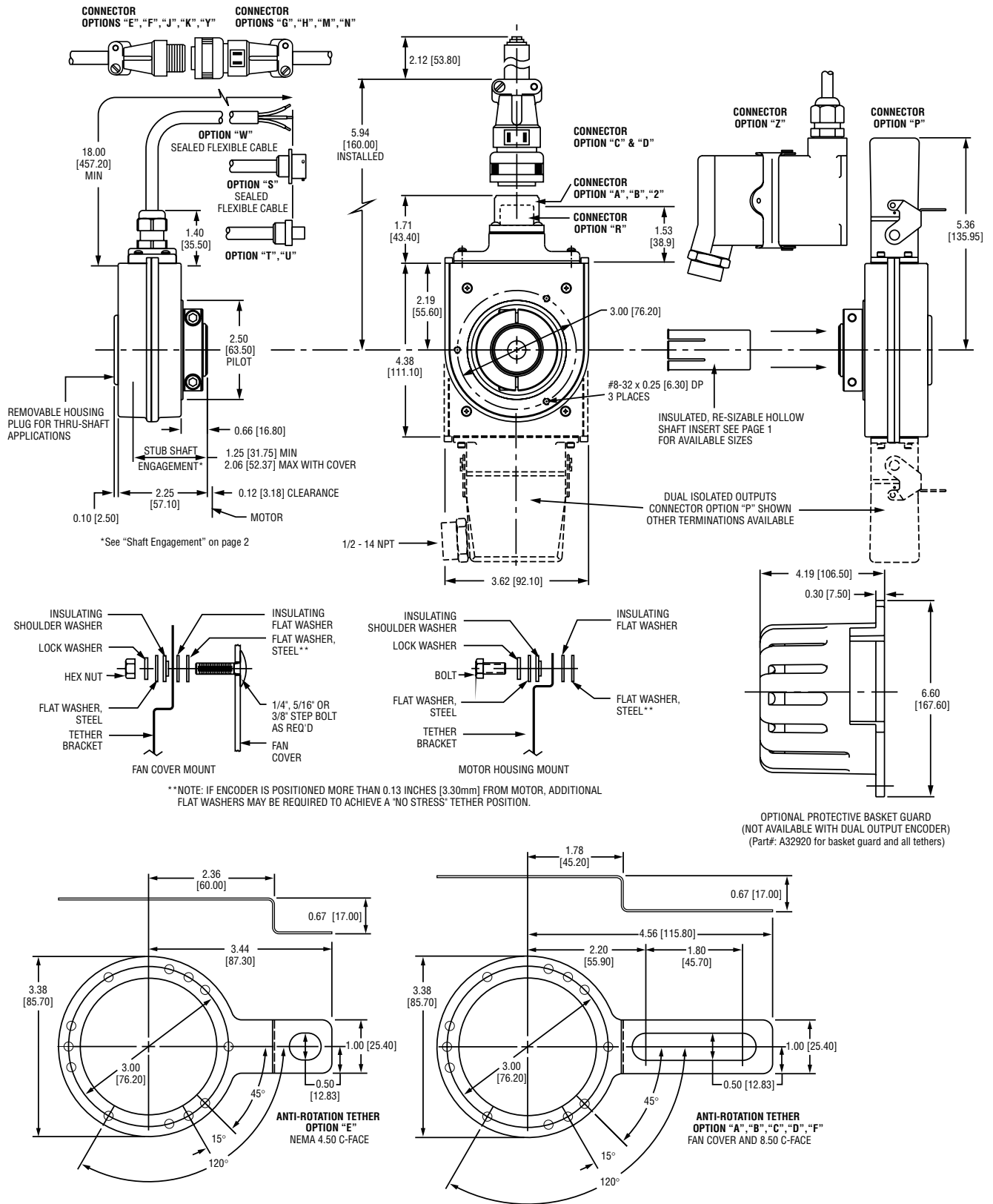

Motor shaft tolerance to be +0.0000/-0.0005 [+0.0000/-0.0127] per NEMA Std. MG1.
 All dimensions are in inches [millimeters] approx.

Avtron standard warranty applies. Copies available upon request.
 Specifications subject to change without notice.



CONNECTOR OPTIONS TETHER OPTION T SHOWN

CONNECTOR OPTION 4 90° M23-12 PIN

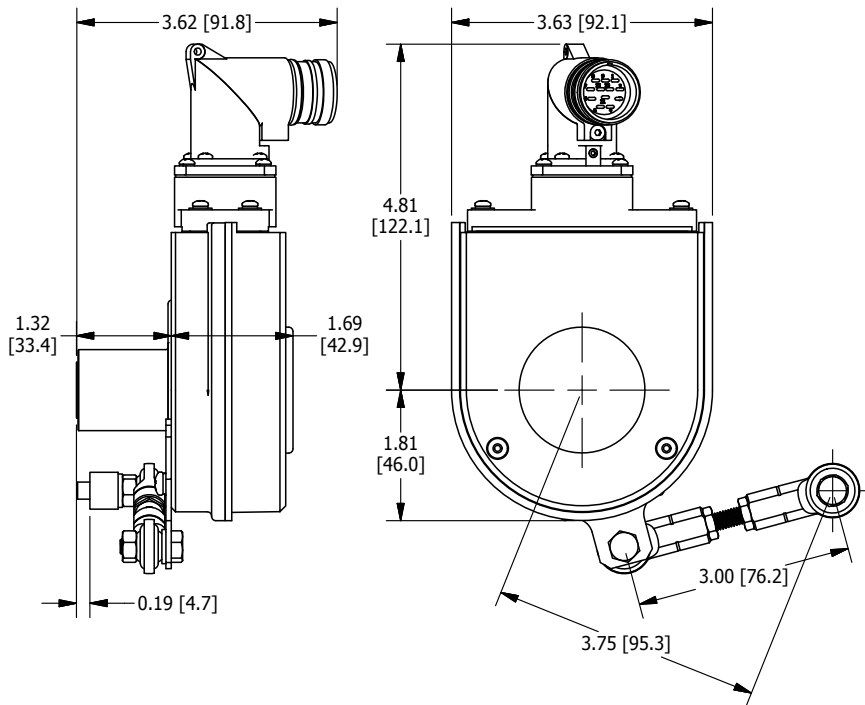

CONNECTOR OPTION 5 TERMINAL BOX

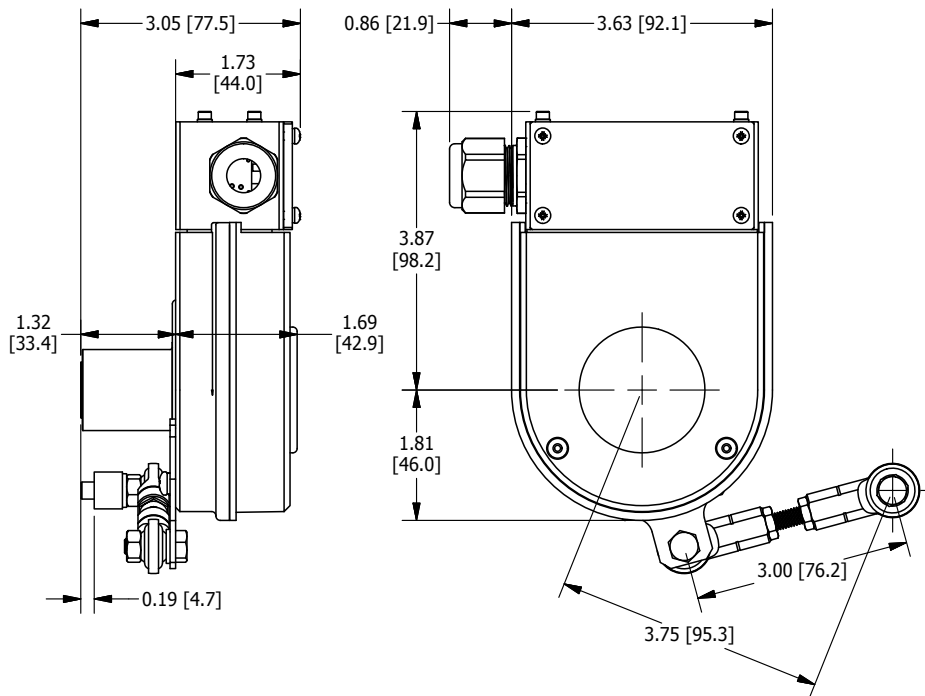

Avtron standard warranty applies. Copies available upon request.
Specifications subject to change without notice.



TETHER OPTION "P"

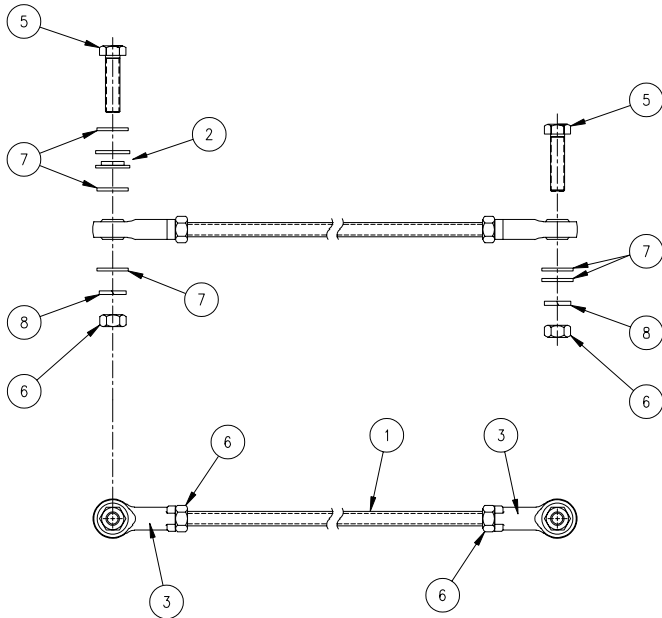
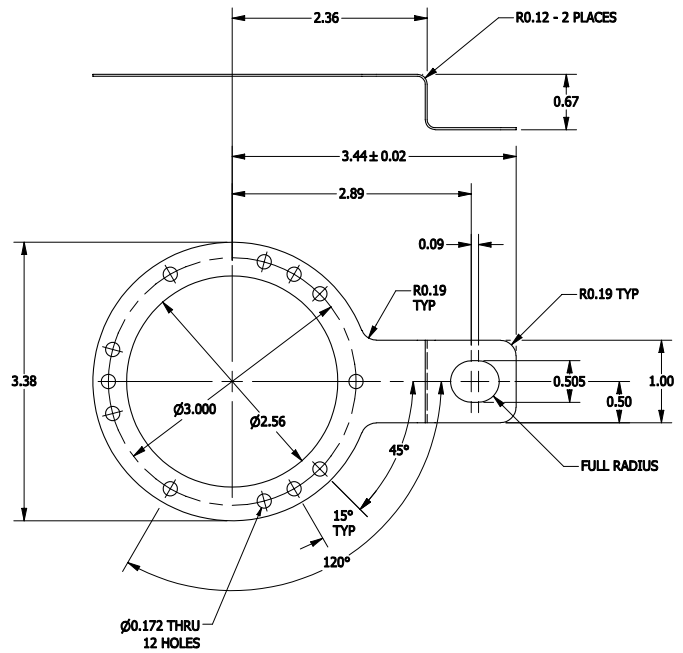
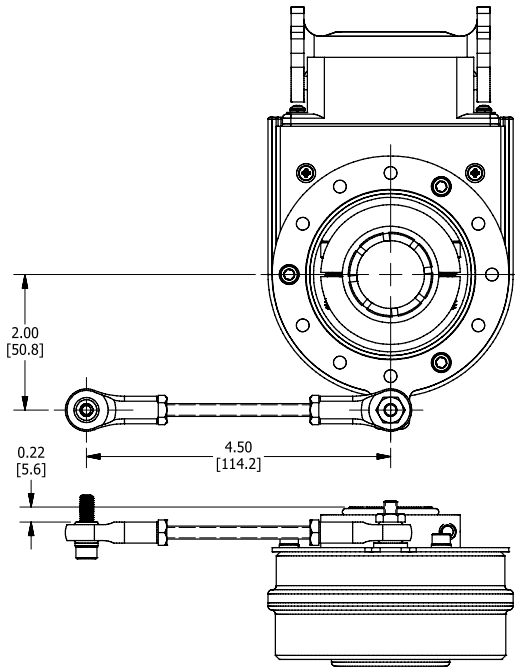

8	2	532581	WASHER, LOCK 5/16
7	5	530075	WASHER, FLAT 5/16
6	4	516124	NUT, HEX 5/16-24
5	2	508243	SCREW, HEX HD 5/16-24 x 1.25
4			
3	2	403122	ROD END
2	1	A32526-2	WASHER SET, INSULATING
1	1	A20476	ROD, THREADED
ITEM NO.	NO. REQ'D	PART NO.	DESCRIPTION

LIST OF MATERIAL



Nidec Makes the Most Reliable Encoders in the World

Nidec Industrial Solutions

243 Tuxedo Avenue | Cleveland, Ohio 44131
 encoderhelpdesk@nidec-industrial.com - www.avtronencoders.com
 +1 216-642-1230



REV. 09-03-2020