



8901 E. PLEASANT VALLEY ROAD  
 INDEPENDENCE, OHIO 44131-5508  
**TELEPHONE:** (1) 216-642-1230 • **FAX:** (1) 216-642-6037  
**E-MAIL:** tachs@avtron.com • **WEB:** www.avtronencoders.com

# Encoder Instructions

**M4-1 and M4-2**  
**INACTIVE DESIGN**  
 Replaced by Model **AV485**

5/8" SOLID SHAFT

## DESCRIPTION

The Avtron Model M4-1 and M4-2 Solid Shaft Encoders are heavy duty speed and position incremental transducers (also known as tachometers or rotary pulse generators). When coupled to a motor or machine, their output is directly proportional to shaft position (pulse count) or speed (pulse rate). The M4 operates down to zero speed and can be used for both control and instrumentation applications.

Mechanically, the M4-1 mounts on a NEMA 56C adapter flange. The M4-2 can be foot mounted by using an optional foot mounting bracket kit P/N A22232 or P/N A25448.

The enclosures on all Model M4s help protect the internal components from the entry of dust and liquids. This, along with the fact that the M4 uses magnetostrictive sensing technology, makes the M4 ideal for demanding industries like paper, metals, and chemical processing.

All M4s can be equipped with one or two outputs. Each output is electrically independent and totally isolated.

These outputs are available as single phase; two-phase (A,B) 90° apart for direction sensing; with complements ( $\bar{A}, \bar{B}$ ), (A Quad B Output) and with marker pulse (Z,  $\bar{Z}$ ). Output resolution is determined by the rotor's base PPR (pulses per revolution), times a sensor multiplier. The sensor module can provide: 1/2 the base PPR, the base PPR, or double the base PPR (see table). With two outputs, the same encoder can provide two different PPRs from a given rotor at the same time. Only one rotor per encoder is possible.

Example: an M4 could use a 1024 PPR sensor output on one side for feedback to a drive system, and simultaneously use a 256 PPR sensor on the other side for a process computer.

Refer to separate instructions for additional information on the shaft grounding option.

## AVAILABLE RESOLUTIONS

	-48 OPTION	-51 OPTION	-60 OPTION
<b>LOW</b>	240	256	300
<b>MEDIUM</b>	480	512	600
<b>HIGH</b>	960	1024	1200

## INSTALLATION

### Equipment needed for installation

#### Supplied:

- M4 Encoder
- Anti-Seize Compound (copper)

#### Not Supplied for NEMA 56C Face Mounting:

- |   |  |
|---|--|
| Hex Head Bolt<br>3/8-16 x 1.00 (8)  | 9/16" Hex Wrench Socket<br>or open end style |
| Washer, Flat 3/8 (8)  | Shaft Coupling                               |
| Washer, Lock 3/8 (8)  | Motor Adapter Flange                         |
| Various bolts, wrenches,<br>flats and lock washers for<br>motor side of flange adapter. | Dial Indicator                               |
| Thread Locker (Loctite<br>242 recommended)  |  |

#### Optional:

- Foot Bracket Mounting Kit (A22232/A25448)  
(see foot mounting instructions for additional hardware required)

## DRIVE INSTALLATION INSTRUCTIONS

Do not use a timing belt, pulley, chain, or sprocket to drive M4s.

Use a flexible disc coupling and align the shafts as accurately as possible. **EXAMPLE:** For a size 62 Thomas Miniature Coupling angular misalignment must be less than 1.34°, parallel misalignment less than 0.028", and axial float less than ±0.031". Overhung loads should also be minimized. If a rubber slinger disc is used, position it on the shaft so it will rotate freely.

## M4 PART NUMBERS AND AVAILABLE OPTIONS

Model	Mounting Style	Shaft Style	Line Driver	Left & Right Output Range	Base PPR	Marker	Connector	Modifications
<b>M4-</b>	<b>0-</b> Non-Standard <b>1-</b> Face Mount 5/8" x 2" shaft <b>2-</b> Foot Mount 5/8" x 2.64" (2" net) shaft	<b>S-</b> Single Ended Shaft <b>G-</b> Shaft Ground	<b>1-</b> 5 to 24 VDC <b>2-</b> 5 to 18 VDC <b>3-</b> 18 to 24 VDC <b>4-</b> 5 to 24 V in, 5 V fixed out	<b>X-</b> None <b>L-</b> Low Range (Base PPR x 1/2) <b>M-</b> Medium Range (Base PPR x 1) <b>H-</b> High Range (Base PPR x 2)	<b>48-</b> 480 <b>51-</b> 512 <b>60-</b> 600	<b>Z-</b> Marker <b>-</b> - None		<b>000-</b> None <b>005-</b> -40° C Rating <b>009-</b> Northstar pinout (mini-Epic) <b>030-</b> Dynapar Pinout (MS)

### Connector

10 Pin Connector			5 Pin MS Connector		Conduit Box	3 ft. Flex. Cable
MS	MS mini	EPIC	M737A replacement	M727A replacement	N-	W-
<b>A-</b> without Plug <sup>§</sup> <b>B-</b> with Flex. Conduit Adapter <sup>§</sup> <b>C-</b> with Plug <sup>§</sup> <b>G-</b> K927B replacement with Plug <sup>§</sup>	<b>K-</b> with Flex. Conduit Adapter <sup>§</sup> <b>L-</b> elbow with Plug <sup>§</sup> <b>M-</b> without Plug <sup>§</sup>	<b>R-</b> Baldor Twist Lock without Plug <b>S-</b> Baldor on 3 ft. Pigtail	<b>P-</b> with Plug <b>V-</b> without Plug	<b>E-</b> without Plug <sup>§</sup> <b>F-</b> with Plug <sup>§</sup> <b>H-</b> without Plug <sup>§</sup> <b>J-</b> with Plug <sup>§</sup>	<b>N-</b> with color coded leads <b>T-</b> with Terminal Block	<b>W-</b> Sealed, Pigtail <b>X-</b> Sealed, Industrial Connector without Plug <b>Z-</b> Sealed, Industrial Connector with Plug

<sup>§</sup> side exit <sup>§</sup> bottom exit

**CAUTION**

*Do not force or drive the coupling onto the shaft, or damage to the bearings may result. The coupling should slide easily on the shaft. Remove nicks and burrs if necessary. Consider driving shaft endplay when positioning coupling.*

For more details on alignment specifications, measurement techniques, and special considerations in specifying and installing drive components, refer to separate installation instructions in the Avtron PULSE GENERATOR HANDBOOK.

**NEMA 56C FACE MOUNTING INSTRUCTIONS**

- 1) Disconnect power from equipment and encoder cable.
- 2) Apply anti-seize compound to inner circumference of coupling (both motor and encoder side).
- 3) Loosen set screws in coupling and apply thread locker to set screws.
- 4) Place coupling on motor shaft, inserting to depth per manufacturer's instructions.
- 5) Attach coupling to motor shaft using set screws per manufacturer's instructions.
- 6) Bolt mounting flange (flowerpot) to motor C-Face, using thread locker with fasteners.
- 7) Slide encoder shaft into other side of coupling. **DO NOT FORCE.** Ensure 1/4" keyway aligns with coupling set screw location.
- 8) Ensure C-Face on mounting flange matches and aligns with encoder C-Face precisely.
- 9) Apply thread locker to hex cap screws.
- 10) Align bolt holes of encoder and flange, thread in (4) hex cap screws, using lock washers.
- 11) Tighten set screws on encoder side of coupling.

**FOOT MOUNTING INSTRUCTIONS**

**Equipment needed for installation**

Supplied:

- |                                     |  |
|-------------------------------------|--|
| 1. Foot Bracket (A22232/A25448)     | 4. Nut, Hex 5/16-18 (4)                      |
| 2. Hex Head Bolt 3/8-16 x .75 (4)   | 5. Washer, Flat 5/16 (4)                     |
| 3. Hex Head Bolt 5/16-18 x 1.50 (4) | 6. Washer, Lock 5/16 (4)                     |
|                                     | 7. Washer, flat 3/8 (4) Washer, lock 3/8 (4) |

Not Supplied:

- 1/2" Wrench
- 9/16" Hex Wrench (socket or open end style)
- Dial Indicator

The optional foot mounting bracket kit is Avtron part number A22232 (A25448 for BC46 replacement). Read all of the following instructions and the Avtron PULSE GENERATOR HANDBOOK prior to beginning any work.

The M4 performance and life will be directly affected by the installation. Following this sequence of steps is recommended.

- 1) Disconnect power from equipment and encoder cable.
- 2) The foot mounting bracket must be secured to a flat, rigid, vibration free steel or aluminum base which can be machined to accept 5/16-18 mounting hardware. See next section.
- 3) Temporarily mount the M4 to the foot bracket, install the coupling to the M4 and driver and verify that the location is suitable for installation.
- 4) If the M4 encoder, bracket, and coupling are suited to the area, check motor/encoder shaft alignment with a straight edge from multiple positions around the shaft circumference to verify that it meets specifications.
- 5) While maintaining alignment, precisely mark the position of the foot bracket on its mounting base.
- 6) Remove the M4. Transfer punch or layout the mounting hole pattern as indicated on outline drawing.
- 7) Machine four, 3/8" dia. through holes or tap four, 5/16-18 holes in center of base slots to give some degree of freedom in final alignment.
- 8) Reinstall the M4 with the flexible coupling loosely in place, and tighten down all mounting hardware. Check motor/encoder shaft alignment with a straight edge from multiple positions around the shaft circumference to verify that it meets specifications. Use thread locker supplied on cap screws which mount M4 to foot bracket.
- 9) Ensure any flat or keyway on the motor and encoder shaft are aligned with the set screw holes of the flexible coupling. Apply thread locker to coupling set screws and tighten per manufacturer's recommendations.
- 10) Recheck alignment and tighten all hardware after first several hours of operation.

**SPECIFICATIONS**

**ELECTRICAL**

- A. Operating Power (Vin)
  1. Volts..... See Line Driver Options
  2. Current ..... 120mA, no load
- B. Output Format
  1. 1Ø..... Connector Options H & J
  2. 2Ø (A & B)..... Connector Options E & F
  3. 2Ø & Comp..... Connector Options A,B,C,M,L,K,V,P, (A,Ā, B,Ḃ) N,T,W,X,& Z (differential line driver)
  4. Marker ..... 1/Rev
- C. Signal Type..... Incremental, Square Wave, 50 ±10% Duty Cycle
- D. Direction Sensing..... ØA leads ØB for CW rotation as viewed from the back of the tach looking at the non-drive end of the motor.
- E. Transition Sep..... 15% minimum
- F. Frequency Range..... 0 to 150,000 Hz.
- G. PPR..... 240, 256, 300, 480, 512, 600, 960, 1024, 1200
- H. See Line Driver Options

**MECHANICAL**

- A. Shaft Inertia..... 0.1 oz. In.<sup>2</sup> (Typ).
- B. Acceleration..... 5,000 RPM/Sec.
- C. Starting Torque ..... 2.0 oz. In. (Typ).
- D. Speed ..... 5,000 RPM
- E. Weight ..... 7 lbs (3.2kg).
- F. Coupling Required: Thomas Miniature Flex. or Equivalent

**ENVIRONMENTAL**

- A. Enclosure Rating..... Sealed against dust and water ingress.
- B. Operating Temp. .... -20° to 85°C
- \*-40°C optional

**LINE DRIVER OPTIONS**

	Output Options			
	1	2	3	4
<b>Voltage Input (Vin)</b>	5-24 VDC	5-18 VDC	18-24 VDC	5-24 VDC
<b>Output High (Volts)</b>	(Vin) -2 (typ)	(Vin) -1 (typ)	330 ohm pull up	5 VDC
<b>Output High (milliamps)</b>	80 (max.)	80 (avg.), 1500 (peak)	330 ohm pull up	80 (max.)
<b>Output Low (Volts)</b>	0.5 (typ)	0.5 (typ)	1 (max.)	0.5 (typ)
<b>Output Low (milliamps)</b>	80 (max.)	80 (avg.), 1500 (peak)	50 (avg.)	80 (max.)
<b>Protection</b>	Reverse Voltage, Transient, Short Circuit (high & low)	Reverse Voltage, Transient, Short Circuit (none)	Reverse Voltage, Transient, Short Circuit (low)	Reverse Voltage, Transient, Short Circuit (high & low)
<b>Maximum Cable Drive(Feet)</b>	1000 ft. @ 5 V 500 ft. @ 12 V 200 ft. @ 24 V	2000 ft.	1000 ft.	1000 ft. @ 5 V

**Foot Mount Kits**

- A22232** - Standard Foot Mount
- A25448** - BC42/46 Foot Mount

MINIMIZE DOWNTIME: Should M4 replacement be required, leave the foot mounting bracket installed on its base and mount the new M4 to the bracket. This maintains the original alignment.

### BREATHER/DRAIN CONSIDERATIONS

The M4 is shipped standard with a breather/drain in the bottom. The breather is to equalize pressure if the tach is exposed to temperature variations. The drain allows condensation an escape path from the encoder. The breather/ drain must be located at the lowest point of the encoder and have a clear, unrestricted drainage path. If for any reason the breather/drain cannot be located at the lowest point (Example vehicle mounting) or have a clear, unrestricted drainage path it must be replaced with a 1/8 NPT pipe plug and the M4 operated as a sealed tach.

### WIRING INSTRUCTIONS

#### CAUTION

**Be sure to remove power before wiring the encoder.**

**Be sure to ground the cable shield: It can be connected to case ground at the encoder, or grounded at the receiving device, but should not be grounded on both ends.**

The M4 can be wired for single phase, two-phase, either with or without complements, with or without markers. See connector options and wiring diagrams on the following page.

For bidirectional operation of the encoder, proper phasing of the two output channels is important. Phase A channel leads phase B channel for clockwise shaft rotation as viewed from the anti-drive or accessory end of the motor (M4 mounting end).

### CORRECTIVE ACTION FOR PHASE REVERSAL

- 1) **Remove Power.**
- 2) Exchange wires on cable, either at encoder cable end, or at speed controller end (but not both).
  - a) **Single Ended 2 Phase Wiring** (see wiring diagram) Exchange A and B at the use end of the wires.
  - b) **Differential 2 Phase Wiring** (see wiring diagram) Exchange **either** A with  $\bar{A}$  in the phase A pair **OR** B with  $\bar{B}$  in the phase B pair but **NOT** both.
- 3) Apply Power.
- 4) Verify encoder feedback is correct, using hand rotation of shaft, or jog mode of the speed controller.

Interconnecting cables specified in the wire selection chart are based on typical applications. Refer to the system drawing for specific cable requirements where applicable.

Physical properties of cable such as abrasion, temperature, tensile strength, solvents, etc., are dictated by the specific application. General electrical requirements are: stranded copper, 22 thru 16 gauge (Industrial EPIC Connector options can use 14 AWG), each wire pair individually shielded with braid or foil with drain wire, 0.05 uF maximum total mutual or direct capacitance, outer sheath insulator, 1,000 ft. max. See Wire Selection Chart for some suggested cables.

#### NOTE

**When using the industrial connector ("G", "P", "V", "X", or "Z" options), the minimum wire size is 20 gage, and 20 gage (only) wire ends must be tinned with solder before connection at the screw terminals.**

## WIRING DIAGRAMS

### DIFFERENTIAL TWO PHASE WIRING APPLICATIONS

(USE CONNECTOR OPTION "L" FOR M738 AND M785 REPLACEMENTS AND CONNECTOR OPTION "G" FOR K927B REPLACEMENT)

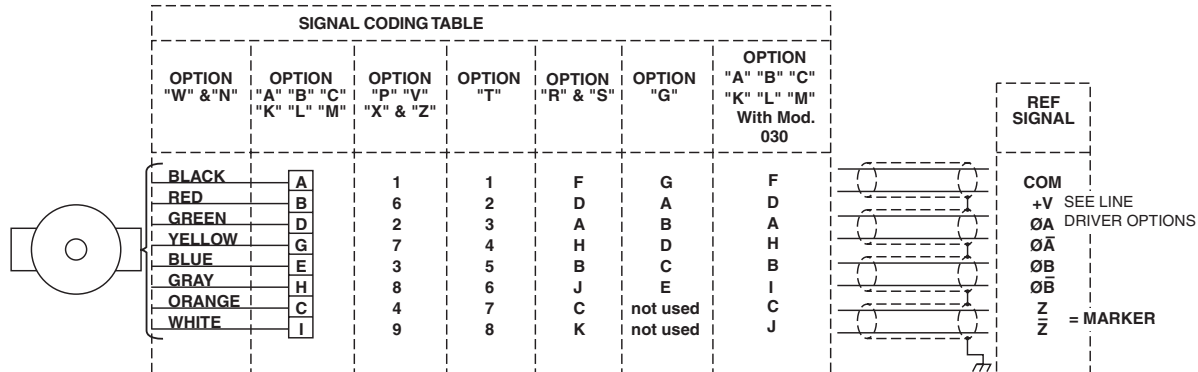

### SINGLE ENDED TWO PHASE WIRING APPLICATIONS

(USE CONNECTOR OPTIONS "E" & "F" FOR M737A REPLACEMENTS)

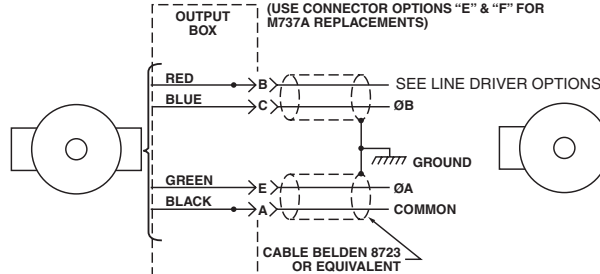

### SINGLE ENDED SINGLE PHASE WIRING APPLICATIONS

(USE CONNECTOR OPTIONS "H" & "J" FOR M727A REPLACEMENTS)

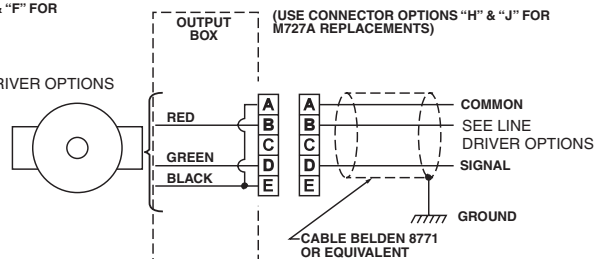

TYPICAL WIRE SELECTION CHART for 18 AWG, multiple pair, individually shielded

	BELDEN	ALPHA
2 PAIR	9368	6062C
3 PAIR	9369	6063C
4 PAIR	9388	6064C
6 PAIR	9389	6066C

**NOTES:** Marker output for connector options "E" & "F" - Pin "D"  
 Marker output for connector options "H" & "J" - Pin "C"  
 Avtron standard warranty applies. Copies available upon request.  
 Specifications subject to change without notice.

# OUTLINE DRAWING

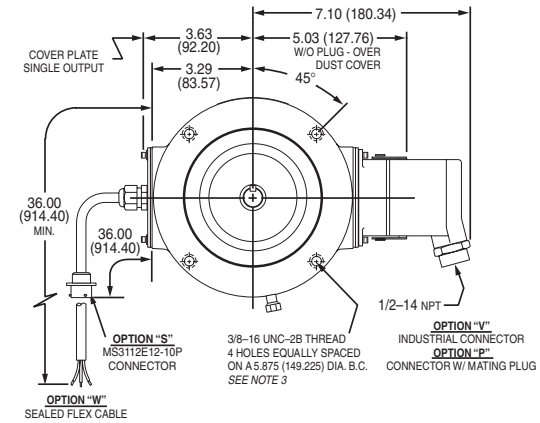
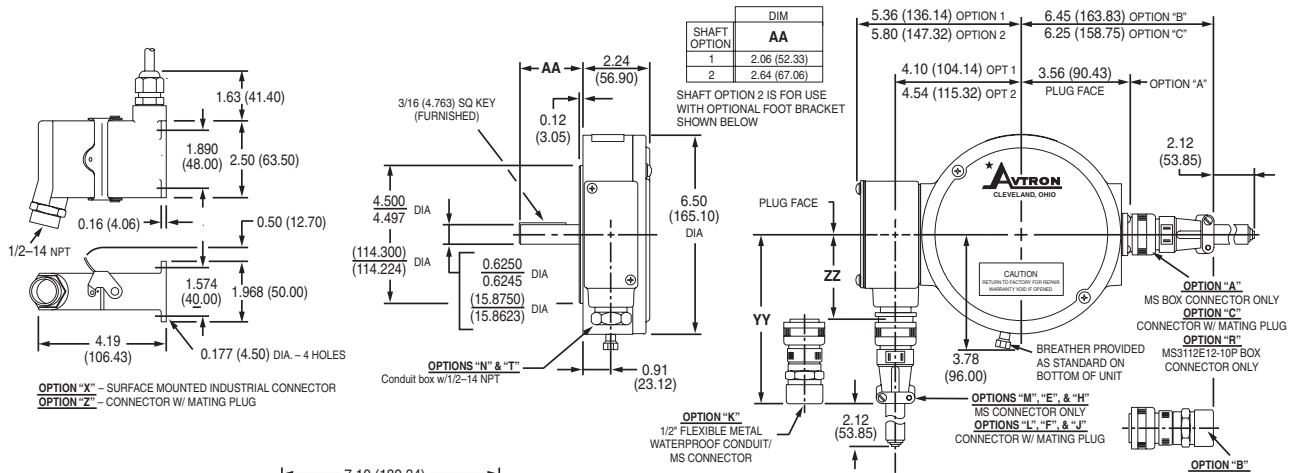

DIMENSION		
OPTION	YY	ZZ
E & H		3.34 (84.84)
F, J, & K	5.62 (142.75)	
M		2.75 (69.85)
L	5.44 (138.18)	

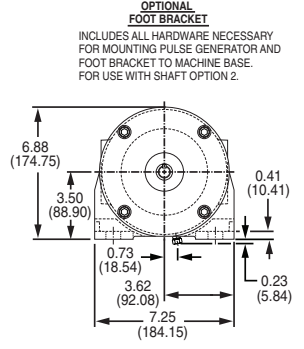

FOOT MOUNT BRACKET P/N A22232			
SHAFT OPTION	BB	CC	
1	1.48 (37.59)	3.00 (76.20)	
2	2.06 (52.33)	3.58 (90.93)	

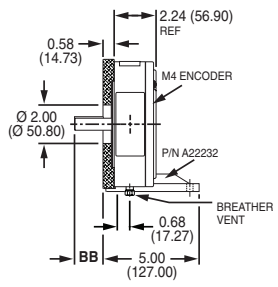
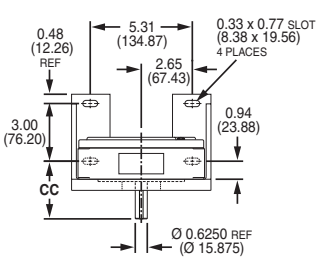

FOOT MOUNT BRACKET P/N A25448			
SHAFT OPTION	BB	CC	
1	1.48 (37.59)	4.78 (121.41)	
2	2.06 (52.33)	5.36 (136.14)	

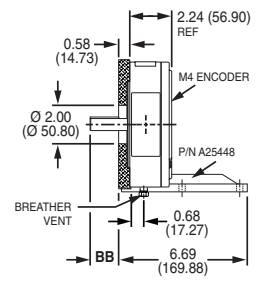
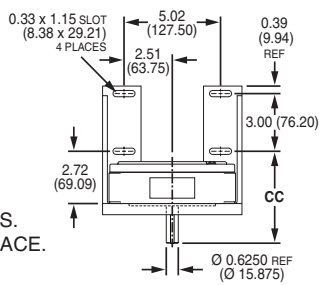

4 - DIMENSIONS IN PARENTHESIS ARE MILLIMETERS.  
 3 - PILOT MOUNTING CONFORMS TO A NEMA 56C FACE.  
 2 - ALL DIMENSIONS ARE APPROX.  
 1 - WEIGHT: 7 LBS.  
 NOTES:

**EU DECLARATION OF CONFORMITY** The Model M4 Encoder has been assessed and type tested against the following Harmonized European Standards: EN 50081-1:1992, EN 50082-1:1998. The Model M4 has been found to be compliant with the requirements of EU Directive 89/336/EEC provided that the following conditions are met: The electrical supply to the M4 must be within specified limits. The electrical supply must offer suitable protection from voltage surges unless the application does not require such protection. On behalf of Avtron Industrial Automation, Inc.: Stephen L D'Henin, Certification Manager, Epsilon Certification Service.

Features and specifications subject to change without notice. Avtron standard warranty applies. All dimensions are in inches (mm) approx.

